

RAYSTATION V2025 SP1

Instructions for Use

US Edition



v2025

Traceback information:
Workspace Minor updates 2 version a70
Checked in 2025-09-15
Skribenta version 5.6.020.1

Declaration of conformity



Complies with Medical Device Regulation (MDR) 2017/745. A copy of the corresponding Declaration of Conformity is available on request.

Safety notices

This user documentation contains WARNINGS concerning the safe use of the product. These must be followed.



WARNING!

The general warning sign informs you of a risk for bodily harm. In most cases the risk is related to mistreatment of the patient.

Note: *The note gives additional information concerning a specific topic, for example, things to consider when performing a certain step in an instruction.*

Copyright

This document contains proprietary information that is protected by copyright. No part of this document may be photocopied, reproduced or translated to another language without prior written consent of RaySearch Laboratories AB (publ).

All Rights Reserved. © 2025, RaySearch Laboratories AB (publ).

Printed material

Hard copies of Instructions for Use and Release Notes related documents are available upon request.

Trademarks

RayAdaptive, RayAnalytics, RayBiology, RayCare, RayCloud, RayCommand, RayData, RayIntelligence, RayMachine, RayOptimizer, RayPACS, RayPlan, RaySearch, RaySearch Laboratories, RayStation, RayStore, RayTreat, RayWorld and the RaySearch Laboratories logotype are trademarks of RaySearch Laboratories AB (publ)*.

Third-party trademarks as used herein are the property of their respective owners, which are not affiliated with RaySearch Laboratories AB (publ).

RaySearch Laboratories AB (publ) including its subsidiaries is hereafter referred to as RaySearch.

* Subject to registration in some markets.

TABLE OF CONTENTS

1	INTRODUCTION	9
1.1	About this manual	10
1.2	RayStation system main applications	11
1.3	RayStation documentation	11
1.3.1	RayStation system documentation	11
1.3.2	Other associated documentation	12
2	PRODUCT INFORMATION	15
2.1	Intended Use	16
2.2	Intended users	16
2.3	Intended patient population and medical conditions	16
2.4	Contraindications	16
2.5	Hardware and operating system	16
2.6	Manufacturer contact information	17
2.7	Reporting of incidents and errors in system operation	17
2.8	Regulatory representatives	18
2.9	Product label	20
2.10	Lifetime	21
2.11	Regulatory information	22
2.12	Regulatory information for machine learning	22
2.13	Accuracy of dose computations	23
2.13.1	Accuracy for the photon dose engines	23
2.13.2	Accuracy for the electron dose engine	27
2.13.3	Accuracy for the brachytherapy TG43 dose engine	28
2.13.4	Accuracy for the brachytherapy Monte Carlo dose engine	29
2.13.5	Accuracy for the proton Pencil Beam dose engine for Uniform Scanning/Double Scattering/Wobbling	29
2.13.6	Accuracy for the proton Pencil Beam dose engine for Pencil Beam Scanning	30
2.13.7	Accuracy for the proton Monte Carlo dose engine for Pencil Beam Scanning	30
2.13.8	Accuracy for the proton linear energy transfer computation	30
2.13.9	Accuracy for the carbon and helium pencil beam dose engine for Pencil Beam Scanning ..	31
2.13.10	Accuracy for the carbon and helium linear energy transfer computation	31
2.13.11	Accuracy for the BNCT RBE-weighted dose computation	32
3	INFORMATION NEEDED FOR SAFE OPERATION	33
3.1	Safety precautions	34
3.1.1	Warnings concerning user responsibility	36
3.1.2	Warnings concerning installation	43
3.1.3	Warnings concerning general system use	44
3.1.4	Warnings concerning DICOM import	46

3.1.5	Warnings concerning DICOM export	48
3.1.6	Warnings concerning CBCT image conversion	50
3.1.7	Warnings concerning dose computation	53
3.1.8	Warnings concerning patient modeling	88
3.1.9	Warnings concerning treatment planning	91
3.1.10	Warnings concerning proton and light ion planning	94
3.1.11	Warnings concerning TomoHelical and TomoDirect planning	97
3.1.12	Warnings concerning CyberKnife treatment planning	99
3.1.13	Warnings concerning BNCT treatment planning	99
3.1.14	Warnings concerning brachytherapy treatment planning	100
3.1.15	Warnings concerning robust optimization	105
3.1.16	Warnings concerning dose evaluation	106
3.1.17	Warnings concerning biological optimization and evaluation	108
3.1.18	Warnings concerning automated planning	109
3.1.19	Warnings concerning beam commissioning	111
3.1.20	Warnings concerning scripting	116
3.1.21	Warnings concerning QA	119
3.1.22	Warnings concerning EPID QA functionality	120
3.1.23	Warnings concerning RayStation Storage Tool	121
3.1.24	Warnings concerning machine learning	122
3.1.25	Warnings concerning medical oncology	123
3.1.26	Warnings concerning clearance check with MapRT	124
3.1.27	Warnings concerning collision check	126
3.2	Import of patient data	128
3.3	Input data	128
3.4	Scripting	128
3.5	Display format	128
4	INSTALLATION INSTRUCTIONS	129
4.1	Installation manual	130
4.2	System environment acceptance test	130
4.3	Hardware diagnostics checks	130
4.4	Remoting environment setup	130
4.5	Data communication environment	130
5	DISPLAY OF COORDINATES, MOVEMENTS AND SCALES	131
5.1	The patient coordinate system	132
5.2	Patient coordinate system in the DICOM export	133
5.3	The treatment machine coordinate system	134
5.3.1	The machine coordinate systems overview	135
5.3.2	The gantry coordinate system	136
5.3.3	The beam limiting device coordinate system	136
5.3.4	The wedge filter coordinate system	140
5.3.5	The patient support coordinate system	141

5.3.6	The table top eccentric coordinate system	142
5.3.7	The table top coordinate system	142
5.3.8	The CyberKnife radiation source coordinate system	143
5.3.9	The gimbal coordinate system	146
5.3.10	Dose curve coordinate system in RayPhysics	149
5.3.11	Setup imager coordinate systems	149
5.4	The jaw and MLC labeling standard	151
5.4.1	The IEC 61217 jaw labeling standard	151
5.4.2	The IEC 601 jaw labeling standard	152
6	SYSTEM INTEGRITY AND SAFETY	153
6.1	Protection against unauthorized use	154
6.2	Backup routines and database maintenance	154
6.3	Database access permissions	155
6.4	ECC RAM	155
6.5	System decommissioning	156
APPENDIX A	- DEFINITIONS	157

1 INTRODUCTION

About RayStation

RayStation integrates all RaySearch's advanced treatment planning solutions into a flexible treatment planning system. The versatile system supports planning for a wide variety of treatment techniques for photon, electron, proton, carbon ion, helium ion, BNCT and brachytherapy. It combines features such as multi-criteria optimization with full support for 4D adaptive radiation therapy. RayStation also includes machine learning functionality as well as optimization algorithms for SMLC, DMLC, VMAT, 3D-CRT, TomoHelical, TomoDirect, CyberKnife, PBS and HDR brachy.

In this chapter

This chapter contains the following sections:

1.1	About this manual	p. 10
1.2	RayStation system main applications	p. 11
1.3	RayStation documentation	p. 11

1.1 ABOUT THIS MANUAL

This manual contains general product information, safety-related information, installation instructions, information about coordinate systems and machine scales and information about system integrity and safety. Study this manual carefully before using the RayStation v2025 system. Proper functioning of the device can only be guaranteed if the instructions in this manual are adhered to. Study the *RSL-D-RS-v2025-RN*, *RayStation v2025 SP1 Release Notes* carefully, these notes provide final instructions on how to use the RayStation v2025 system.

Some modules described in this manual are not included in the standard configuration of RayStation v2025 and may require additional licenses.

1.2 RAYSTATION SYSTEM MAIN APPLICATIONS

The RayStation system consists of the following main applications:



RayStation – the main application where all the activities associated with treatment planning can be performed.

The RayStation application is described in *RSL-D-RS-v2025-USM, RayStation v2025 User Manual*.



RayPhysics – the commissioning application where activities such as beam model commissioning, brachytherapy equipment commissioning and CT commissioning can be performed.

The RayPhysics application is described in *RSL-D-RS-v2025-RPHY, RayStation v2025 RayPhysics Manual*.



RayMachine - contains the Model Administration module which manages Machine Learning models for dose prediction and segmentation.

The RayMachine application is described in *RSL-D-RS-v2025-USM, RayStation v2025 User Manual*.



RayBiology – the manager for administration of models for radiobiological evaluation and optimization, and relative biological effectiveness (RBE).

The RayBiology application is described in *RSL-D-RS-v2025-USM, RayStation v2025 User Manual*.



RayStation Physics mode – the application where it is possible to compute dose with uncommissioned treatment machines, to allow more machine modeling and testing activities than possible in the Beam commissioning module in RayPhysics.

The RayStation Physics mode application is described in *RSL-D-RS-v2025-USM, RayStation v2025 User Manual*.



Clinic Settings – the clinic settings administration tool.

The Clinic Settings application is described in *RSL-D-RS-v2025-USM, RayStation v2025 User Manual*.



RayStation Storage Tool – the database administration tool.

The RayStation Storage Tool application is described in *RSL-D-RS-v2025-USM, RayStation v2025 User Manual*.

1.3 RAYSTATION DOCUMENTATION

1.3.1 RayStation system documentation

The RayStation v2025 system documentation consists of:

Document	Description
<i>RSL-D-RS-v2025-IFU, RayStation v2025 SP1 Instructions for Use US Edition</i>	This manual contains regulatory information and safety information concerning the RayStation v2025 system.

Document	Description
<i>RSL-D-RS-v2025-OPPIFU, RayStation v2025 Ocular Proton Planning Instructions for Use</i>	This manual contains regulatory information and safety information concerning the RayStation v2025 system for ocular proton planning.
<i>RSL-D-RS-v2025-EPIDUSM, RayStation v2025 EPID QA User Manual</i>	This manual describes the EPID QA functionality.
<i>RSL-D-RS-v2025-RN, RayStation v2025 SP1 Release Notes</i>	This document provides a summary of new features, known issues and changes since the previous version of RayStation.
<i>RSL-D-RS-v2025-USM, RayStation v2025 User Manual</i>	This manual describes the functionality of the RayStation v2025 system and gives step-by-step instructions on how to perform the most common operations.
<i>RSL-D-RS-v2025-RPHY, RayStation v2025 RayPhysics Manual</i>	This manual describes the RayPhysics v2025 application.
<i>RSL-D-RS-v2025-REF, RayStation v2025 Reference Manual</i>	This manual contains algorithm descriptions and physics reference information.
<i>RSL-D-RS-v2025-MLREF, RayStation v2025 Machine Learning Reference Manual</i>	This manual is a reference manual for machine learning in RayStation v2025.
<i>RSL-D-RS-v2025-DLPMDS, RayStation v2025 Deep Learning Planning Model Data Sheet</i>	This manual contains the model specifications for deep learning planning in RayStation v2025.
<i>RSL-D-RS-v2025-DLSMDS, RayStation v2025 Deep Learning Segmentation Model Data Sheet</i>	This manual contains the model specifications for deep learning segmentation in RayStation v2025.
<i>RSL-D-RS-v2025-OPPREF, RayStation v2025 Ocular Proton Planning Reference Manual</i>	This manual is a reference manual for ocular proton planning in RayStation v2025.
<i>RSL-D-RS-v2025-OPT, RayStation v2025 A Guide to Optimization in RayStation</i>	This manual contains detailed information about optimization in RayStation v2025.

1.3.2 Other associated documentation

- *RSL-D-RS-v2025-SEAT, RayStation v2025 System Environment Acceptance Test Protocol*
- *RSL-D-RS-v2025-SG, RayStation v2025 Scripting Guidelines*
- *RSL-D-RS-v2025-BAMDS, RayStation v2025 Brachy Applicator Model Data Specification*
- *RSL-D-RS-v2025-BCDS, RayStation v2025 Beam Commissioning Data Specification*

- *RSL-D-RS-v2025-DCS, RayStation v2025 DICOM Conformance Statement*
- *RSL-D-RS-v2025-SEG, RayStation v2025 System Environment Guidelines*
- *RSL-D-RS-v2025-ATP, RayStation v2025 Product Acceptance Test Protocol*
- *RSL-D-RS-v2025-SUO, RayStation v2025 System Upgrade Options*
- *RSL-D-RS-v2025-MLS, RayStation v2025 Machine Learning Settings*
- *RSL-D-RS-v2025-CIRSI, RayStation v2025 Customer Instruction for RayStation Installation*
- *RSL-D-RS-v2025-SBOM, RayStation v2025 Software Bill of Materials*
- *RSL-P-RS-CSG, RayStation Cyber Security Guidelines*
- *RSL-P-RS-RGI, RayStation RayGateway Installation Instructions*

Note: *In the case of a service pack, only the affected manuals will be updated. For a complete list of the manuals updated in the service pack, refer to the release notes (available in RayStation Release Notes and RayCommand Instructions for Use respectively) for that specific service pack.*

2 PRODUCT INFORMATION

This chapter describes important information about the RayStation v2025 system.

In this chapter

This chapter contains the following sections:

2.1	Intended Use	p. 16
2.2	Intended users	p. 16
2.3	Intended patient population and medical conditions	p. 16
2.4	Contraindications	p. 16
2.5	Hardware and operating system	p. 16
2.6	Manufacturer contact information	p. 17
2.7	Reporting of incidents and errors in system operation	p. 17
2.8	Regulatory representatives	p. 18
2.9	Product label	p. 20
2.10	Lifetime	p. 21
2.11	Regulatory information	p. 22
2.12	Regulatory information for machine learning	p. 22
2.13	Accuracy of dose computations	p. 23

2.1 INTENDED USE

RayStation is a software system for radiation therapy and medical oncology. Based on user input, RayStation visualizes and proposes treatment plans. After a proposed treatment plan is reviewed and approved by authorized intended users, RayStation may also be used to administer treatments.

The system functionality can be configured based on user needs.

Japan: For the intended use in Japan, refer to RSJ-C-00-03 Japanese regulatory IFU for RayStation.

2.2 INTENDED USERS

The intended users of RayStation shall be clinically qualified staff trained in using the system.

The users must have a working knowledge of English or another user interface language provided.

2.3 INTENDED PATIENT POPULATION AND MEDICAL CONDITIONS

The intended patients for RayStation are patients where a qualified and licensed medical practitioner has decided it is appropriate to give radiation therapy or medical oncology treatment for tumors, lesions and other conditions.

2.4 CONTRAINDICATIONS

The user is responsible for determining the individual treatment plan and techniques for each patient and this also includes identifying any contraindications for the individual treatment.

2.5 HARDWARE AND OPERATING SYSTEM

RayStation v2025 shall be installed on a high end PC with a recommended screen resolution of 1920 x 1200 pixels (or 1920 x 1080). RayStation v2025 can be used with different versions of Windows operating systems. For details about recommended hardware and OS setups, see *RSL-D-RS-v2025-SEG, RayStation v2025 System Environment Guidelines*.

The system can either be run from the installation PC or from a client with remote access to the installation PC, where the remote access software operates at a level suitable for assessment of medical imagery (including lossless graphic transfer).

Scripting in CPython has been tested for the versions that are installed together with RayStation. Other versions and/or different packages can be installed using Scripting Environments, refer to the *RSL-D-RS-v2025-USM, RayStation v2025 User Manual* for more information.

The system must only be used with a computer approved to applicable hardware safety standards with respect to electric failure and electromagnetic radiation.

It is recommended to install new Windows Service Packs. These are tested, cumulative sets of security and critical updates widely released by Microsoft. Also, the Security Updates, which are widely released fixes for operating system security-related vulnerabilities are recommended to install. It is discouraged from installing any other updates. After all updates, system performance must be verified, see *section 4.2 System environment acceptance test on page 130*.

Microsoft SQL Server

It is recommended to install new SQL server service packs. These are released and tested by Microsoft and include cumulative sets of hotfixes and fixes to reported issues. After all updates, system performance must be verified [see section 4.2 System environment acceptance test on page 130].

GPUs used for computations

GPUs used for computation must have ECC RAM and the ECC state must be enabled in the GPU driver settings. The version of the GPU drivers, identified in the System Environment Guidelines, must be used at all times. If multiple GPUs are used for computations, it is recommended that all are of the same model. If multiple GPUs of different models are used, consecutive computations may not give identical results, depending on which graphics card(s) have been used. For a detailed list of supported graphics cards, refer to the *RSL-D-RS-v2025-SEG, RayStation v2025 System Environment Guidelines*. Additional validations have been performed and are identified with certificates available from support@raysearchlabs.com.

Deformable image registration may be computed on GPUs without ECC RAM.

2.6 MANUFACTURER CONTACT INFORMATION

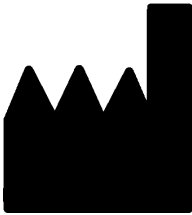

RaySearch Laboratories AB (publ)
Eugeniavägen 18C
SE-113 68 Stockholm
Sweden
Telephone: +46 8 510 530 00
E-mail: info@raysearchlabs.com
Country of origin: Sweden

2.7 REPORTING OF INCIDENTS AND ERRORS IN SYSTEM OPERATION

Report incidents and errors to the RaySearch support email: support@raysearchlabs.com or to your local support organization via telephone.

Any serious incident that has occurred in relation to the device must be reported to the manufacturer.

Depending on applicable regulations, incidents may also need to be reported to national authorities. For the European Union, serious incidents must be reported to the competent authority of the European Union Member State in which the user and/or patient is established.

2.8 REGULATORY REPRESENTATIVES

The table below describes the regulatory representatives and their contact information.

Regulatory representatives	Contact information
Australian Sponsor	Emergo Australia Level 20, Tower II Darling Park 201 Sussex Street Sydney, NSW 2000 Australia
Brazil Importer	Emergo Brazil Import Importação e Distribuição de Produtos Médicos Hospitalares Ltda Avenida Francisco Matarazzo, 1752, sala 502 e 503, Água Branca, São Paulo, SP CEP:05.001-200. CNPJ: 04.967.408/0001-98 Email: brazilvigilance@ul.com Responsável Técnico: Luiz Levy Cruz Martins – CRF/SP: 42415 Anvisa nº: 80117580996
Chinese representative	RaySearch (Shanghai) Medical Device Co., Ltd Room 608, No. 1118, Pudong South Road Pilot Free Trade Zone, Shanghai China
Hong Kong representative	Emergo Hong Kong Limited 18/F Delta House 3 ON YIU Street Shatin, NT Hong Kong
Indian representative	RAYSEARCH INDIA PVT. LTD. Level-2, Elegance Tower, Mathura Road, Jasola, New Delhi- 110025 India Office No. 208 & 209
Israeli representative	I.L Emergo Israel Ltd. Andrei Sakharov 9 Matam P.O.B 15054 Haifa 3190501 Israel

Regulatory representatives	Contact information
Japanese representative	RaySearch Japan K.K. Saiwai building, 1-3-1 Uchisaiwaicho Chiyoda-ku Tokyo 100-0011 Japan
Korean representative	RaySearch Korea, LLC Unit 1005, 10th Floor Hybro Building, 503, Teheran-ro, Gangnam-gu Seoul Republic of Korea
New Zealand Sponsor	CARSL Consulting PO Box 766 Hastings New Zealand
Singapore representative	RaySearch Singapore Pte. Ltd. 260 Orchard Road #07-01/04 The Heeren, Singapore 238855 Singapore
Taiwanese representative	Tomorrow Medical System Co., Ltd. 6F, No. 88, Xing'ai Road, Neihu Dist. Taipei City, 114067 Taiwan
Thai representative	Kamol Sukosol Electric Co., Ltd. 665 Mahachai Road, 2nd Floor Samranraj, Pranakorn Bangkok 10200 Thailand
US Agent	RaySearch Americas, Inc. The Empire State Building 350 5th Avenue, Suite 5000 New York, New York 10118 USA

2.9 PRODUCT LABEL





The version number of an installed RayStation v2025 system can be found by choosing **Help:About RayStation** in the RayStation menu.

The following information can be identified:

- Product name = RayStation
- **产品型号: RayStation** (for the Chinese market only)
- Release version = **17.0**
- Marketing name = RayStation v2025 SP1
- Software build number = **17.0.1.113**
- Clinical build = Indicates that the software is designed for clinical use.

Note: A clinical installation requires both a clinical build and a clinical license. Otherwise, 'Not for clinical use' will be displayed in the title bar.

- Product lifetime = The lifetime per market is one year after the next major release, but no less than three years
- Radiation treatment planning system software = The generic name of the product
- **产品名称: 放射治疗计划软件** (for the Chinese market only)
- **MD** = Indicates that the product is a medical device
- **UDI** = Unique Device Identification number
- **CH|REP** = The Swiss authorized representative and importer
- Driver information = The installed version for the Mevion Spot Map Converter and CyberKnife RAIL. Expand this field by clicking the arrow.

-  = The CE mark and the notified body number
-  = Production date
-  = Consult instructions for use
-  = The name and address of the manufacturer
-  = The support e-mail address

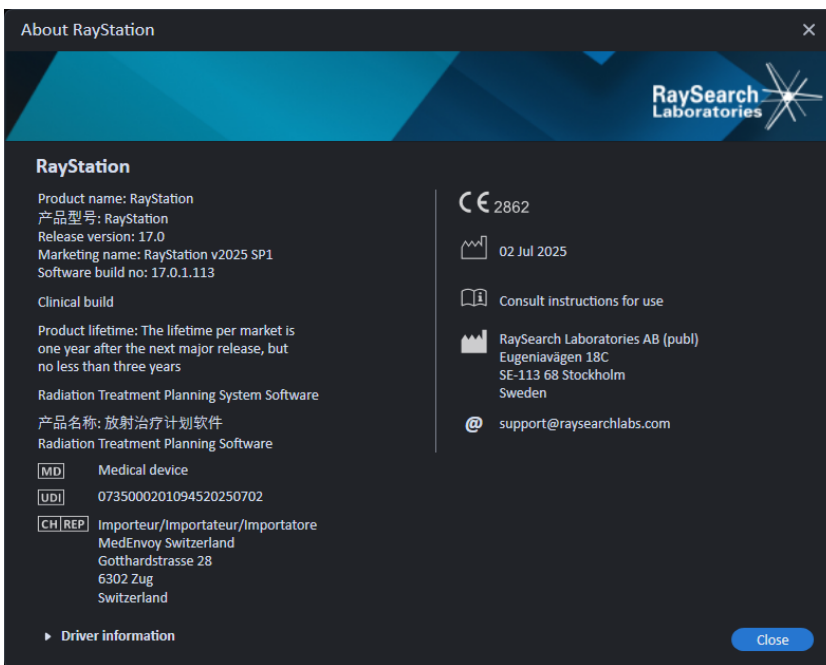

Figure 1. The **About RayStation** dialog.

2.10 LIFETIME

The lifetime per market is one year after the next major release, but no less than three years. Support for a product version in a market ends 36 months after market clearance, provided a new major version is released within 24 months. If not, support is prolonged and ends 12 months after the next major version is released in that market. When a version is no longer supported in a given market, it is considered to be end of life in that market.

2.11 REGULATORY INFORMATION

Disclaimer

Canada: Carbon and helium ion treatment planning, proton Wobbling, proton Line Scanning, BNCT planning and the Microdosimetric Kinetic Model are not available in Canada for regulatory reasons. These features are controlled by licenses and these licenses (rayCarbonPhysics, rayHeliumPhysics, rayWobbling, rayLineScanning, rayBoron and rayMKM) are not available in Canada. In Canada, machine learning models for dose prediction must be cleared by Health Canada prior to clinical use. Deep Learning Segmentation is limited to Computed Tomography imaging in Canada.

Japan: For the regulatory information in Japan, refer to RSJ-C-02-003 Disclaimer for the Japanese market.

The United States: Carbon and helium ion treatment planning, BNCT planning and the Microdosimetric Kinetic Model are not available in the United States for regulatory reasons. These features are controlled by licenses and these licenses (rayCarbonPhysics, rayHeliumPhysics, rayBoron and rayMKM) are not available in the United States. In the United States, machine learning models for dose prediction must be cleared by the FDA prior to clinical use. In the United States, RayStation is not intended for plan adaptations performed within one patient session, also referred to as online adaptive planning. Treatment machine OXRAY is not supported in the United States.

European SRN-number

The single registration number (SRN) = SE-MF-000001908 has been issued to RaySearch Laboratories AB (publ), as required by the EU MDR – Regulation (EU) 2017/745.

2.12 REGULATORY INFORMATION FOR MACHINE LEARNING

Regulatory note

Machine learning functionality in RayStation is subject to regulatory clearance in some markets.

For any markets where machine learning functionality is not approved, the relevant licenses controlling the machine learning functionality are disabled, ensuring that unauthorized use is not possible.

Purpose of machine learning models

Machine learning models in RayStation can be used for image segmentation or dose prediction. For the purpose of segmentation, the models can be used to contour anatomical structures. Such models, however, cannot be used to contour or detect lesions. A model may only be used for the scope defined within the associated data sheet for that model.

Machine learning model approval

When a machine learning model has been commissioned and approved, it is locked and cannot further evolve. The models are thus prevented from any modifications during clinical use.

Available models

Due to regulatory restrictions in some markets, dose prediction using machine learning may be limited.

2.13 ACCURACY OF DOSE COMPUTATIONS

All dose engines in RayStation v2025 have been verified to be at the same level of accuracy as that of independent well-renowned treatment planning systems. Dose computations must still be validated by the user for all clinically relevant situations, refer to *section 3.1.1 Warnings concerning user responsibility on page 36* for more information.

Note: *RayStation beam models are general with respect to machine type and properties. It may be possible to create beam models for treatment machine setups that have not been explicitly validated by RaySearch.*

2.13.1 Accuracy for the photon dose engines

RayStation has two photon dose engines: collapsed cone (CC) and Monte Carlo (MC). The validation strategies for the two dose engines are described below, followed by a description of the validation scope for different machines and treatment techniques. The Monte Carlo dose engine does not support TomoTherapy machines.

Validation strategy for the collapsed cone photon dose engine

RayStation validation has been performed against a substantial set of measurements including point doses in homogeneous and heterogeneous phantoms, line doses, film and measurements using the Delta4, MapCheck, ArcCheck, MatriXX, Octavius1500 and PTW 729 detectors. This includes the IAEA test suite, which includes measured doses for an Elekta machine for a number of test cases for energies 6 MV, 10 MV and 18 MV¹. The acceptance criteria of the validations against measurements are formulated in terms such as the gamma criterion (pass if the gamma value is below 1 for 95% of the data points for gamma 3%, 3 mm), point dose differences and confidence levels¹. The overall accuracy is acceptable. Some algorithm limitations have been identified and are described in this section, in the warning 4001 in *section 3.1.1 Warnings concerning user responsibility on page 36* and in the Algorithm weaknesses section in *RSL-D-RS-v2025-REF, RayStation v2025 Reference Manual*.

The collapsed cone photon dose engine in RayStation v2025 has also been compared to independent well-renowned treatment planning systems, such as Eclipse (Varian), Pinnacle³ Radiation Treatment Planning System 7.2 (Philips), Monaco (Elekta), Oncentra (Elekta) and Precision (Accuray). The comparison includes plans for Siemens, Elekta, Varian and TomoTherapy machines. Agreement between the dose computed by the independent treatment planning systems and the RayStation

¹ IAEA-TECDOC-1540, Specification and Acceptance Testing of Radiotherapy Treatment Planning Systems, April 2007.

dose is defined to mean that the global γ^2 value is below 1 for 95% of the volume for gamma criterion (3%, 3 mm), and for 98% of the volume for gamma criterion (5%, 5 mm). Since all cases return gamma distributions within the acceptance criteria, the dose engine computations can be regarded as equivalent to the clinical systems to which they were compared.

The validation has focused on typical clinical usage, with common LINAC models such as Varian (600 CD, CLINAC, 2100, 2100 EX, 2300C/D, Trilogy, TrueBeam with MLCs MLC120, HD120, Millennium MLC, m3 and Varian Halcyon), Elekta (with MLCi/MLCi2, Beam Modulator and Agility heads), and Siemens (Primus with 3D-MLC and Artiste), for energies between 4 MV and 20 MV, and water phantoms and patient geometries. Flattening filter free delivery is validated using for example Siemens Artiste and Varian Halcyon. Most data is collected using MLCs with leaf widths of 5 mm and 10 mm. RayStation v2025 has also been validated with the Brainlab m3 add-on MLC on a Varian Novalis machine. The m3 MLC has not been validated with any other machine, for example a machine without backup jaw such as the Siemens machines. No other add-on MLC has been validated.

Validation for wedges, blocks and cones

For wedges the validation is performed solely in water. The validation is focused on central square fields with a few exceptions. Special care should be taken when verifying and evaluating wedge beam models. Block validation is performed by comparing doses from RayStation v2025 to Eclipse (Varian) and Oncentra (Elekta) and as part of the IAEA test suite. The IAEA test suite also includes Elekta wedges. Only divergent photon blocks are supported. Cone validation is limited to Elekta LINACs. The .decimal GRID block is validated for Elekta Agility and Varian TrueBeam.

Dose calculation for rotational plans

Standard VMAT delivery technique has been validated for Varian, Elekta and Vero LINACs. Sliding window VMAT sequencing has been validated for Elekta Agility and Varian Halcyon LINACs. VMAT sequencing should be considered on par with a new treatment technique and therefore beam model and machine behavior validation, and per-patient QA must be performed.

The validation has shown that the RayStation dose calculation for small field rotational plans is highly sensitive to beam model MLC parameters.

RayStation v2025 offers the VMAT burst mode technique, where every second segment contains MLC motion without beam on and every other segment has beam on without MLC motion. The burst mode technique is only intended and validated for Siemens machines.

VMAT with wave arcs, i.e. VMAT with ring rotation for the Vero and OXRAY, can currently only be delivered by these machines. The same motion could in principle be created using couch motion. The wave arc implementation in RayStation v2025 is only intended for and validated for Vero and OXRAY LINACs.

² Low D.A., Harms W.B., Mutic S, and Purdy J.A., A technique for the qualitative evaluation of dose distributions, Med. Phys. 25 (1998) 656-661.

Dose calculation for Vero

For RayStation v2025, validation for the Vero machine has been performed. The CC dose engine has been successfully validated in comparison to measurements for static MLC, VMAT and wave arc plans. Only wave arc plans with ring rotations up to ± 15 degrees have been validated.

Dynamic IMRT (DMLC) for Vero has not been validated and DMLC is not available for Vero machines in RayStation v2025. The Vero validation is limited to the Vero MLC with 30 leaf pairs with all leaf widths 0.5 cm. Dynamic tracking delivery has not been part of the RayStation v2025 validation. It is up to the user to validate the delivered dose for Vero plans with dynamic tracking enabled.

Dose calculation for OXRAY

Hitachi is developing a new LINAC called OXRAY. For RayStation v2025, validation for the OXRAY has been performed with a non-clinical version of the machine. The OXRAY LINAC has a gimbal system that can be used to set gimbal angles for a treatment beam and direct it away from the treatment machine central axis. There are two gimbal angles, gimbal pan and gimbal tilt. The OXRAY validation includes plans with gimbal angles up to the maximum angle of ± 3 degrees for both pan and tilt. The CC and MC dose engines have been successfully validated in comparison to measurements for static MLC, Static Arc, Conformal Arc, VMAT and Wave arc plans both with and without gimbal angles.

Only wave arc plans with ring rotations up to ± 15 degrees have been validated. Dynamic IMRT (DMLC) has not been validated and DMLC is not available for OXRAY in RayStation v2025. Dynamic tracking delivery has not been part of the RayStation v2025 validation. It is up to the user to validate the delivered dose for OXRAY plans with dynamic tracking enabled. As the validation has been performed with a non-clinical version of the machine, special care must be taken before using RayStation v2025 with the OXRAY LINAC.

Dose calculation for TomoTherapy

RayStation v2025 dose calculation has been validated for TomoHelical and TomoDirect plans with the latest version of the TomoTherapy machine, called Radixact, and with older TomoTherapy systems which have been upgraded to work with iDMS. Older, not upgraded, machines are not supported. If you are not sure if your TomoTherapy treatment machine can be used with RayStation, contact Accuray or RaySearch support.

The validation has been performed for all field widths supported by the TomoTherapy machine, fixed and dynamic jaws as well as for different pitch, projection time, average open time, modulation factors and target size and positions.

Motion synchronization delivery has not been part of the RayStation v2025 validation. It is up to the user to validate the delivered dose for TomoHelical plans with motion synchronization enabled.

Additional requirements for TomoTherapy dose computation in RayStation v2025 are described in the warning 10172 in section 3.1.1 *Warnings concerning user responsibility* on page 36.

Dose calculation for CyberKnife

RayStation v2025 dose calculation has been validated for CyberKnife M6/S7 treatment machines. Older CyberKnife versions are not supported by RayStation v2025.

The collapsed cone dose engine has been successfully validated in comparison with measurements for treatment plans collimated with fixed cones, iris cones and MLC. Measurements have been performed with film and ion chamber, in different homogeneous and heterogeneous phantoms, for example the CIRS lung phantom. The validation includes different node sets and motion synchronization techniques.

The selected motion synchronization technique does not have any effect on the computed dose in RayStation. For accuracy of target tracking using motion synchronization techniques available for the CyberKnife treatment machine, refer to Accuray.

In addition to comparison with measurements, RayStation dose has been compared with dose computed by the Accuray dose engines Finite Size Pencil Beam (FSPB) and Monte Carlo, showing excellent agreement.

Validation strategy for the photon Monte Carlo dose engine

The photon Monte Carlo dose engine uses the same fluence computation in the LINAC head as the collapsed cone dose engine. The description of MLC details, blocks, cones, virtual wedges and physical wedge transmission has been validated thoroughly in combination with the collapsed cone dose engine. The same fluence computation has been validated also in combination with the Monte Carlo dose computation using a representative subset of the measurements from the collapsed cone dose computation. The subset is selected to cover different energies (4 MV to 20 MV), LINAC models (Varian with MLC120, HD120 and m3, Elekta with MLC Agility and MLCi/i2, and CyberKnife), wedges (Varian standard wedge, EDW and Elekta motorized wedge), cones and blocks, treatment techniques (3D-CRT, SMLC, DMLC and arc treatments) and homogenous and heterogeneous geometries. The IAEA test suite (Elekta 6 MV, 10 MV, 18 MV) was included and a high resolution AAPM TG105 test suite (TrueBeam with 6 MV, 10 MV, 10 MV FFF) with heterogeneous inserts for different geometries (slabs, inclined incidence, nose-shaped surfaces, steps) in water was added compared to the collapsed cone dose validation.

Measurements included scanned profiles, depth doses and point measurements in water and in the CIRS phantom, and film, Delta4, ArcCheck and MapCheck measurements. The acceptance criteria were the same as the ones used for the collapsed cone validation and the overall accuracy was acceptable. Most limitations described in *section 2.13.1 Accuracy for the photon dose engines on page 23* also apply for the photon Monte Carlo dose engine. For details see *RSL-D-RS-v2025-REF, RayStation v2025 Reference Manual*. See also warning 4001 in *section 3.1.1 Warnings concerning user responsibility on page 36*.

In addition to the measurement based validation, the photon Monte Carlo computation in patient has been cross-checked against EGSnrc for different geometries (slabs, off-axis heterogeneous inserts, curved surfaces), materials (water, lung, bone, aluminum, titanium), energies (0.5 MeV to 20 MeV) and fields sizes (0.4 cm x 0.4 cm to 40 cm x 40 cm), both with and without magnetic field. Since the measurement uncertainty is no longer present, the acceptance criteria in the validation tests using simulated dose are stricter than those for measurement; 95% of all voxels are required to have a gamma value below 1 for gamma 2%, 2mm.

For MR LINACs, the photon Monte Carlo dose engine has been validated against PTW Octavius measurements for SMLC plans collapsed to gantry angle zero, both for Elekta Unity and MagnetX

Aurora. The Elekta Unity barrel scatter component has been validated against air measurement with a Farmer chamber with buildup at different SSDs, and the overall dose computation with different gantry angles, couch and imaging coils has been verified using comparison to Monaco dose computation. The lateral electron return effect for MagnetTx Aurora has been verified for vertical slab geometries using the DOSXYZnrc simulation from [Steciw S, Fallone BG, Yip E. *Dose perturbations at tissue interfaces during parallel linac-MR treatments: The "Lateral Scatter Electron Return Effect" (LS-ERE)*. *Med Phys*. 2024 Nov;51(11):8506-8523. doi: 10.1002/mp.17363. Epub 2024 Aug 17. PMID: 39153227].

The Monte Carlo dose calculation does not support TomoTherapy machines. The computation has not been validated for Vero and Siemens LINACs. It is up to the user to validate RayStation v2025 Monte Carlo dose computation with Vero and Siemens machines.

2.13.2 Accuracy for the electron dose engine

The electron dose computation in RayStation v2025 has been successfully validated for accuracy in clinically relevant settings. The goal of the validation is to provide evidence of clinically acceptable dose accuracy for LINACs using the dual foil scattering technique with applicators and cutouts. The electron phase space model in RayStation is designed to model this arrangement. The implementation is parameter driven and thus generic with respect to a typical dual foil, applicator and cutout arrangement.

The RayStation v2025 system has been validated for typical clinical usage of applicator with cutout collimated fields. The validation covers energies between 4 MeV and 25 MeV, in water phantoms with and without inhomogeneities and in patient geometries with LINACs from all major vendors. Only Cerrobend cutouts with straight edges, i.e., parallel to the beam axis line, are supported and validated.

Validation has been performed for the following combinations of LINACs and electron energies:

	4 MeV	6 MeV	9 MeV	12 MeV	15 MeV	18 MeV	20 MeV	25 MeV
Varian Clinac 2100			x				x	
Elekta Synergy		x		x		x		
Elekta Agility	x	x	x	x				
Elekta BM		x	x	x	x			
Siemens Primus		x		x		x		
EGSnrc (generic electron treatment machine)			x			x		x

The electron Monte Carlo dose engine has been compared to the Oncentra (Elekta) treatment planning system using the same gamma criteria as for photons, see *section 2.13.1 Accuracy for the photon dose engines on page 23*. The comparison with Oncentra includes plans for an Elekta Synergy

machine. Since all cases return gamma distributions within the acceptance criteria, the electron dose computations can be regarded as equivalent to the clinical system to which it was compared.

In addition, the electron dose engine in RayStation v2025 has been validated against measurements for treatment machines with x and y jaws (Elekta and Varian), Elekta machines with Beam Modulator and machines without x jaws (Elekta Agility and Siemens). In water 98% of computed doses values shall pass $\gamma(5\%, 5 \text{ mm}) < 1$ when compared to measured doses, and 95% shall pass $\gamma(3\%, 3 \text{ mm}) < 1$.

The electron Monte Carlo dose computation in patient has also been thoroughly validated against the independent Monte Carlo code EGSnrc for different geometries, materials and energies. The same acceptance criteria are used when comparing to EGSnrc doses as when comparing to measurements.

All validation tests return results within the acceptance criteria, except for one minor deviation for Elekta Agility. For one 9 MeV test case with a bone slab phantom, the relative difference between measured and computed dose is 4.5%. This is above the acceptance criterion of 3%, but within the tolerance level of 5%. The same test case for electron energies 6 MeV and 12 MeV passes the acceptance criterion, and test cases for electron energy 9 MeV pass the acceptance criteria for the two other slab phantoms, one of which contains both a bone slab and a lung slab and should be more challenging than the failing test case with only the bone slab. Additionally, one of the test cases comparing EGSnrc dose to RayStation v2025 uses bone at 9 MeV and this test passes the acceptance criterion. The measurement point lies at the distal fall-off, which means that the measurement is very sensitive to minor misalignments or misinterpretation of the density used in the phantom. Therefore, we conclude that it is highly probable that the measurement point in this case is inaccurate.

The overall accuracy is acceptable and it is concluded that the electron Monte Carlo dose engine is safe for clinical use.

2.13.3 Accuracy for the brachytherapy TG43 dose engine

The brachytherapy TG43 dose engine has been validated against published QA long-away data for six common HDR sources, including the E&Z Bebig Co0-A86 and Ir2.A85-2 sources. The acceptance criteria are formulated in terms of local gamma criteria and relative dose differences. All six sources pass the acceptance criteria.

The dose engine has also been validated against clinical independent treatment planning systems, implementing the TG43 formalism (SagiPlan, E&Z Bebig and Oncentra Brachy, Elekta). The validation is performed both for single dwell positions in a phantom and treatment plans for cervix, prostate and breast treatments. Additionally, it has been compared to an independent Monte Carlo dose engine (EGS Brachy) for a relevant patient case. Local gamma criteria are used for comparison to the independent systems. Since all cases return gamma distributions within the acceptance criteria, the brachytherapy TG43 dose computation performs equally well as the independent systems to which it was compared.

Validation has also been performed against the EQUAL-ESTRO laboratory measurement procedure. The measurement point passes the acceptance criterion formulated as a relative dose difference.

The overall accuracy of the RayStation TG43 dose engine is in accordance with clinical standards. However, the TG43 formalism has intrinsically some limitations, which must be known by the user. The acceptance criteria and dose engine algorithm limitations are found in section *TG43 dose engine accuracy and limitations* in the *RSL-D-RS-v2025-REF, RayStation v2025 Reference Manual*.

2.13.4 Accuracy for the brachytherapy Monte Carlo dose engine

The brachytherapy Monte Carlo dose engine has been validated for E&Z Bebig Co0-A86 and Ir2.A85-2 sources for clinically relevant setups.

The validation test suite contains comparison to published QA along-away data in water, to 3D dose computed with the TG43 dose engine for a patient case, to 3D dose computed with an independent Monte Carlo dose engine (EGS Brachy) for two different treatment sites (H&N and breast), and to 3D dose computed with EGS Brachy for single dwell points in water close to interfaces to different materials (air, bone, lung and tungsten).

The acceptance criteria are formulated in terms of local or global gamma criteria depending on the test case. Both validated sources pass the acceptance criteria.

The overall accuracy of the RayStation Monte Carlo dose engine is in accordance with or better than clinical standards. In general, Monte Carlo dose algorithms provide a better representation of the dose deposition in the real patient geometry, compared to the TG43 formalism, where the whole patient volume is considered as water.

2.13.5 Accuracy for the proton Pencil Beam dose engine for Uniform Scanning/Double Scattering/Wobbling

The proton Pencil Beam dose engine for Uniform Scanning/Double Scattering/Wobbling in RayStation v2025 has been validated against a substantial set of measurements in water using simple and irregular block, MLC and compensator shapes for un-rotated and rotated snout. Setups where the block is mounted upstream and downstream of the compensator is included. The validation has been performed for an IBA Universal nozzle in uniform scanning mode, a Mitsubishi SELECT BEAM NOZZLE in uniform scanning mode, a Mevion S250 nozzle in double scattering mode, a Sumitomo HI Multipurpose nozzle in Wobbling mode, and an IBA eye line. Validation has also been performed against dose in heterogeneous media calculated by the independent treatment planning system XiO (Elekta).

The acceptance criteria for these validations are formulated in terms of requirements on properties such as gamma criteria, SOBP range and distal fall off, field width half maximum (FWHM) and left and right penumbra differences. The overall accuracy is acceptable; however, some dose engine algorithm limitations have been identified and are described in *Proton US/SS/DS/Wobbling dose computation warnings on page 67*. The acceptance criteria and dose engine algorithm limitations are found in section *Dose engine accuracy and limitations* in the *RSL-D-RS-v2025-REF, RayStation v2025 Reference Manual*.

2.13.6 Accuracy for the proton Pencil Beam dose engine for Pencil Beam Scanning

The proton PBS Pencil Beam dose engine in RayStation v2025 has been validated against a substantial set of measurements in water for open beam setups, as well as for setups that use a range shifter. Validation has also been performed using anthropomorphic phantoms as well as against dose in heterogeneous media calculated by the independent treatment planning system XiO (Elekta). The validation has been performed for an IBA Dedicated nozzle for PBS and a Sumitomo HI Dedicated nozzle for Line Scanning.

The acceptance criteria for these validations are formulated in terms of requirements on properties such as distal range, gamma criteria and field size factors. The overall accuracy is acceptable; however, some dose engine algorithm limitations have been identified and are described in *Proton PBS dose computation warnings on page 74*. The acceptance criteria and dose engine algorithm limitations are found in section *Dose engine accuracy and limitations* in the *RSL-D-RS-v2025-REF, RayStation v2025 Reference Manual*.

2.13.7 Accuracy for the proton Monte Carlo dose engine for Pencil Beam Scanning

The proton PBS Monte Carlo dose engine in RayStation v2025 has been validated against a substantial set of measurements in water for open beam setups, for set-ups that use a range shifter, as well as for setups using block or MLC aperture for open beam setups and for setups that use a range shifter.

The block and MLC aperture setups were validated for systems where the block and MLC is positioned upstream of the range shifter. This is important to be aware of and special care should be taken when verifying and evaluating machine models for setups where the block aperture is mounted downstream of the range shifter.

Validation has also been performed using anthropomorphic phantoms, as well as against dose in heterogeneous media calculated by the independent treatment planning system XiO (Elekta). The validation has been performed for an IBA Dedicated nozzle for PBS, an IBA Universal nozzle for PBS, a Sumitomo HI Dedicated nozzle for Line Scanning, a Sumitomo HI Multipurpose nozzle for Line Scanning and a Mevion S250i Hyperscan beam delivery system.

The acceptance criteria for these validations are formulated in terms of requirements on properties such as distal range, gamma criteria and field size factors. The overall accuracy is acceptable; however, some dose engine algorithm limitations have been identified and are described in *Proton PBS dose computation warnings on page 74*. The acceptance criteria and dose engine algorithm limitations are found in section *Dose engine accuracy and limitations* in the *RSL-D-RS-v2025-REF, RayStation v2025 Reference Manual*.

2.13.8 Accuracy for the proton linear energy transfer computation

The linear energy transfer (LET) computation in the proton PBS Monte Carlo dose engine in RayStation v2025 has been validated against reference FLUKA simulations. This includes single energy layers and SOBPs of different field sizes in water, as well as in different materials like bone and lung. In

order to be comparable, the corresponding averaged value of LET has been scored in the reference FLUKA simulations, see *RSL-D-RS-v2025-REF, RayStation v2025 Reference Manual*.

The acceptance criteria for these validations are formulated in terms of requirements on gamma. The overall accuracy is acceptable; however, some algorithm limitations have been identified and are described in *Proton PBS dose computation warnings on page 74*. The acceptance criteria and dose engine algorithm limitations are found in section *Dose engine acceptance criteria* in *RSL-D-RS-v2025-REF, RayStation v2025 Reference Manual*.

2.13.9 Accuracy for the carbon and helium pencil beam dose engine for Pencil Beam Scanning

The carbon pencil beam dose engine (used for light ions, i.e. carbon and helium) in RayStation v2025 has been validated against a substantial set of measurements in water for open beam setups, as well as for setups that use a range shifter. Measurements with a carbon ion beam were taken at CNAO (Centro Nazionale di Adroterapia Oncologica, Pavia, Italy), and measurements with a helium ion beam were taken at HIT (Heidelberger Ion Beam Therapy Center, Heidelberg, Germany).

The acceptance criteria for these validations are formulated in terms of requirements on properties such as distal range, gamma criteria and absolute dose and can be found in *Dose engine acceptance criteria* in the *RSL-D-RS-v2025-REF, RayStation v2025 Reference Manual*. The overall accuracy is acceptable; however, some dose engine algorithm limitations have been identified and are described in *Light ion PBS dose computation warnings on page 79*.

Validation of physical and RBE-weighted dose for carbon ions has been performed against dose in heterogeneous media calculated by the independent treatment planning system Syngo RTPS (Siemens AG). Validation of RBE-weighted dose has also been performed against dose in homogeneous media (water) calculated with TRiP98 (developed by GSI Helmholtzzentrum für Schwerionenforschung GmbH, Darmstadt, Germany) for the LEM model, and with iDose (developed by NIRS, National Institute of Radiological Science, Chiba, Japan) for the MKM model. Since the returned gamma distributions are within the acceptance criteria, the carbon ion PBS dose engine computations can be regarded as equivalent to the clinical systems to which it was compared.

For helium, a user-defined RBE model with initial RBE curves calculated according to the LEM-IV model from GSI has been validated against TRiP98. RBE-weighted helium dose according to MKM has been validated against an independent implementation by HIT.

2.13.10 Accuracy for the carbon and helium linear energy transfer computation

The linear energy transfer (LET) computation in the carbon pencil beam dose engine in RayStation v2025 has been validated against reference FLUKA simulations. This includes single energy layers and SOBPs of different field sizes in water, as well as in different materials like bone and lung. In order to be comparable, the corresponding averaged value of LET has been scored in the reference FLUKA simulations, see *RSL-D-RS-v2025-REF, RayStation v2025 Reference Manual*.

The acceptance criteria for these validations are formulated in terms of requirements on gamma. The overall accuracy is acceptable; however, some algorithm limitations have been identified and are described in *Light ion PBS dose computation warnings on page 79*. The acceptance criteria and

dose engine algorithm limitations are found in section *Dose engine acceptance criteria* in *RSL-D-RS-v2025-REF, RayStation v2025 Reference Manual*.

2.13.11 Accuracy for the BNCT RBE-weighted dose computation

The Standard BNCT RBE-weighted dose computation is computed through the linear combination of RBE-model parameters, planning parameters, and the physical dose components computed by an external dose engine. Since it is an exact computation, its accuracy is expected to only be limited by machine precision (including the precision in the data-transfer between the external dose-engine and RayStation). The effect is expected to be smaller than 0.005% relative to the maximum dose. This has been confirmed through comparisons with the RBE-weighted dose computed by the external dose engines. Note that this only refers to the accuracy of the RBE-weighted dose computation itself, and not to the accuracy of the physical dose components provided by the external dose engine that are input to this computation.

The accuracy of the computation of cell type doses is additionally affected by a material rescaling approximation, which replaces full particle transport and dose computation, as described in section *Cell type dose computation* in the *RSL-D-RS-v2025-REF, RayStation v2025 Reference Manual*. This approximation assumes a linear relationship between the hydrogen (or nitrogen) physical dose component and the hydrogen (or nitrogen) elemental weight in the material definition. Furthermore, if the elemental weight for a material is zero, no rescaling is possible, and the corresponding component is ignored in the cell type dose computation. Provided no materials are used with extremely different properties or with zero hydrogen or nitrogen elemental weight, the impact of this approximation on the accuracy of the computation is not expected to be clinically relevant. A comparison of the cell-type doses computed in RayStation to reference dose values from an external dose engine demonstrated differences smaller than 0.5% relative to the maximum default RBE-weighted dose in the plan.

3 INFORMATION NEEDED FOR SAFE OPERATION

This chapter describes information needed for safe operation of the RayStation v2025 system.

Note: *Be aware that additional safety-related release notes may be distributed separately within a month of software installation.*

Note: *When using RayStation with RayCare, the versions of the products must be compatible. Check service pack versions with RaySearch Service.*

In this chapter

This chapter contains the following sections:

3.1	Safety precautions	p. 34
3.2	Import of patient data	p. 128
3.3	Input data	p. 128
3.4	Scripting	p. 128
3.5	Display format	p. 128

3.1 SAFETY PRECAUTIONS

Adhere to the following warnings for safe operation of the RayStation v2025 system.

In this section

This section contains the following sub-sections:

3.1.1	Warnings concerning user responsibility	p. 36
3.1.2	Warnings concerning installation	p. 43
3.1.3	Warnings concerning general system use	p. 44
3.1.4	Warnings concerning DICOM import	p. 46
3.1.5	Warnings concerning DICOM export	p. 48
3.1.6	Warnings concerning CBCT image conversion	p. 50
3.1.7	Warnings concerning dose computation	p. 53
3.1.8	Warnings concerning patient modeling	p. 88
3.1.9	Warnings concerning treatment planning	p. 91
3.1.10	Warnings concerning proton and light ion planning	p. 94
3.1.11	Warnings concerning TomoHelical and TomoDirect planning	p. 97
3.1.12	Warnings concerning CyberKnife treatment planning	p. 99
3.1.13	Warnings concerning BNCT treatment planning	p. 99
3.1.14	Warnings concerning brachytherapy treatment planning	p. 100
3.1.15	Warnings concerning robust optimization	p. 105
3.1.16	Warnings concerning dose evaluation	p. 106
3.1.17	Warnings concerning biological optimization and evaluation	p. 108
3.1.18	Warnings concerning automated planning	p. 109
3.1.19	Warnings concerning beam commissioning	p. 111
3.1.20	Warnings concerning scripting	p. 116
3.1.21	Warnings concerning QA	p. 119
3.1.22	Warnings concerning EPID QA functionality	p. 120
3.1.23	Warnings concerning RayStation Storage Tool	p. 121
3.1.24	Warnings concerning machine learning	p. 122
3.1.25	Warnings concerning medical oncology	p. 123
3.1.26	Warnings concerning clearance check with MapRT	p. 124
3.1.27	Warnings concerning collision check	p. 126

3.1.1 Warnings concerning user responsibility



WARNING!

Ensure sufficient training. The user organization shall ensure that individuals authorized to perform treatment planning functions are appropriately trained for the functions they perform. Only individuals authorized to perform treatment planning functions and appropriately trained in treatment planning techniques should use this software. Carefully read all instructions prior to use. The user is responsible for proper clinical use and the prescribed radiation dose. (508813)



WARNING!

Input data quality. Always be aware that the quality of the output depends critically on the quality of the input data. Any irregularities in the imported data or uncertainties about input data units, identification, image orientation or quality of any other nature shall be thoroughly investigated before the data is used. (508811)



WARNING!

Plan review and approval. All treatment plan data shall be carefully reviewed and approved by a qualified person before it is used for radiotherapy treatment purposes. A plan (beam set) that is 'optimal' with respect to the optimization goals may still be inappropriate for clinical use.

(4780)

**WARNING!**

Beam models must be validated before clinical use. It is the responsibility of the user to validate and commission all beam models before they are used to create clinical external beam radiotherapy treatment plans.

RayStation is developed to be used by trained Radiation Oncology professionals. We strongly suggest that users adhere to recommendations published in AAPM TG40, TG142, TG53, TG135, IAEA TRS 430, IAEA TRS 483 and other standards to ensure accurate treatment plans.

Computed dose accuracy depends directly on the beam model quality. Beam model insufficiency may lead to deviations between approved and delivered dose. All parameter values and plan QA and QC shall be reviewed and approved by qualified physicists. The dose calculation must be validated for all commissioned CT machines.

- The computed dose shall be validated for all relevant clinical situations including, but not limited to, variation in SAD, SSD, field-size, field-shape, off-axis position (x, y and diagonal), collimation type, degree of modulation, leakage dose (variation in MU/Gy or NP/Gy), couch/gantry/collimator angles, CyberKnife node sets, patient/phantom material composition and patient/phantom material geometry.
- The computed dose shall be validated for all clinically relevant dose grid resolutions.
- Known limitations are described in the *RSL-D-RS-v2025-REF, RayStation v2025 Reference Manual*. Additional limits of operation for each beam model must be identified during validation and adhered to during planning.

For photons:

Special care should be taken before using RayStation with MLC leaves smaller than 5 mm, materials that differ from common patient materials, blocks, small circular cones, wedges (in particular off-axis wedges), complex VMAT plans, rotational plans with small field sizes, Siemens mARC plans and wave arc plans, especially with larger ring rotation than 15 degrees.

Note that:

- a beam model validated for 3D-CRT is not necessarily suitable for IMRT plans.
- a beam model validated for SMLC is not necessarily suitable for DMLC plans.
- a beam model validated for SMLC or DMLC is not necessarily suitable for VMAT plans.
- a beam model validated for VMAT is not necessarily suitable for plans created using sliding window VMAT sequencing.

- a beam model commissioned for one photon dose engine (Collapsed Cone or Monte Carlo) is not suitable for the other dose engine without adaptation of the beam model parameters.

Validation must be performed for each selected treatment technique using Physics mode or RayStation. For C-arm and CyberKnife LINACs, see warning 3438. For TomoTherapy treatment machines, see also warning 10172.

For protons:

Validation shall include relevant compensator and range shifter geometries, block and/or MLC aperture contours, air gaps/snout positions, isocenter to surface distance, spot tune and patterns, spread out Bragg peak depth and modulation width, field sizes [see also warning 1714].

For Mevion Hyperscan, see also warning 369009.

For light ions:

Validation shall include relevant air gaps/snout positions, isocenter to surface distances, spot size and patterns, field sizes, heterogeneous/anthropomorphic phantoms, CT machines, range shifter settings, spill dose and delivery settings [see also warning 1714].

For electrons:

Validation must include relevant applicator geometries, field sizes without cutout, field sizes and field shapes with cutout, field shape orientations for rectangular applicators, cutout materials and thicknesses, air gaps to isocenter and D50 water ranges per nominal beam energy. Only Cerrobend cutouts with straight edges, i.e., parallel to the beam axis line, are supported.

(4001)



WARNING!

Brachytherapy models must be validated before clinical use. Brachytherapy source models and application setups must be validated before clinical use.

It is the responsibility of the user to validate all brachytherapy source models and application setups before clinical use, see warnings 283358, 283879 for more details.

(285635)

**WARNING!**

TomoTherapy machine commissioning. When commissioning a TomoTherapy machine, most parameters are read from iDMS and only minor changes are expected to be required in the machine model in RayPhysics. The transverse profile, jaw fluence output factors and leaf latency offsets are overwritten in this process and may need to be updated.

Note that for TomoTherapy machines the computed dose curves in the Beam commissioning module are normalized against the measured curves, i.e., the measured and computed dose curves will match in output regardless of the output of the beam model. The output of the model must therefore be adjusted and verified for all field widths using TomoHelical beams. For more information, refer to the *RSL-D-RS-v2025-BCDS, RayStation v2025 Beam Commissioning Data Specification*.

Note also that the MLC filters are not part of the dose curve calculation in the Beam commissioning module in RayPhysics and their usage can only be verified using TomoHelical or TomoDirect beams.

The dose calculation must be validated for the relevant range of clinical treatment fields before clinical use. In addition to what is listed in warning 4001, validation shall include different jaw sizes and modes, projection times, opening fractions and pitches.

[10172]

**WARNING!**

Mevion Hyperscan machine commissioning. When commissioning a Mevion S250i ("Hyperscan") machine, the beam model only uses input data for the highest deliverable energy of the system. Nevertheless, the dose calculation must be validated for the whole relevant range of clinical treatment fields before clinical use. It is especially important to verify the ranges, and the absolute output for different field sizes and snout positions, for a number of energies covering all the range shifters of the Mevion energy selector.

It is also important to validate the dose computation for beams with apertures (both static and dynamic). In RayStation, such beams are planned with a block. The Mevion Adaptive Aperture will then try to adapt its position and leaves to reproduce the desired aperture contour. This validation shall comprise fields of different sizes, including fields with non-straight edges (complex target shapes). [369009]



WARNING!

NCT machine commissioning. Commissioning of a machine in RayStation for a specific dose engine version should always be done in agreement with the treatment delivery system and dose engine manufacturer. [611928]



WARNING!

Collision detection for CyberKnife. The collision detection performed in RayStation does not guarantee that collisions are always detected. Before delivery, the user is obliged to validate that the delivery system will perform collision detection.

[339623]



WARNING!

Block/cutout verification. Always verify that the blocks and electron beam cutouts created in the Beam design modules are physically realizable. It is not possible to define any block manufacturing constraints in RayStation.

For proton blocks, the size of the block milling tool is taken into consideration in the automatic block generation tools. However, it is possible to obtain a block that cannot be manufactured using the manual block editing/creation tools. It is then possible to run the milling tool algorithm manually after the block editing. However, since it is not done automatically, the responsibility that the block is physically realizable still lies with the user.

Always check the created block against the block aperture printout. [508816]



WARNING!

Verify the scale of the block/cutout printout. The printer settings will affect the actual size of the block/cutout in the printout. Before using the block/cutout printout for block/cutout manufacturing or verification, always check that the scale of the x- and y-axes are equal and that 1 cm on the verification scale corresponds to 1 cm using a ruler. [508818]

**WARNING!**

ROI/POI verification. Always review all regions of interest (ROIs) and points of interest (POIs) carefully before using them for treatment planning or evaluation purposes.

(4793)

**WARNING!**

Review 4DCT projections. The user shall review the resulting image set from a 4DCT projection before using it for treatment planning or evaluation purposes. The projected image set shall be compared against the image sets in the 4DCT group in order to verify that the Hounsfield Units and corresponding densities are as expected. This can be performed by examining HU values in the patient views and by computing evaluation doses in the Plan evaluation module.

The geometrical properties of the projected image set, such as orientation, position and size shall also be compared against the original 4DCT. This can be performed by fusing the projected image sets with the original 4DCT image sets in the Structure definition module or the Image registration module and verify that they are aligned correctly.

(10414)

**WARNING!**

Image specific density table obtained through HU rescaling. When using an image set specific density table obtained through HU rescaling it is highly important that the user reviews the resulting density table properly before using it for dose computation. The rescaled density table will directly affect the dose computation.

(9506)



WARNING!

Patient setup. Couch shift (table top translation) instructions for positioning the patient are displayed in the Patient setup dialog and in the plan report.

The default couch shift presentation is "Patient", i.e., the couch shift instructions in the Patient setup dialog are expressed in terms of patient anatomical directions.

If desired, the couch shift presentation can be changed to "Couch", i.e., the couch shift instructions in the Patient setup dialog are expressed in couch directions. The couch shift presentation is changed in the Clinic Settings application.

Before clinical use, always verify that the couch shift displayed in RayStation and in the plan report are as intended and in accordance with clinical practice.

Note that another option for patient setup is to export the couch shift according to the DICOM standard. This option can be selected in RayPhysics.

(9101)



WARNING!

Review frame-of-reference registration before dose computation. It is especially important that frame-of-reference registrations that have been imported or created by treatment position alignment are reviewed before they are used for fraction dose computation in the Dose tracking module, or when computing dose on additional image sets.

(9650)



WARNING!

Restricted sale in the U.S. Federal (U.S.) and State laws restrict the sale of this product to a physician or on a physician's order.

(4782)



WARNING!

Single sign-on setting. If the single sign-on setting is used in Clinic Settings, it is possible for an unauthorized user to authenticate in RayStation if a workstation is left unattended. The authentication is done in the name of the logged in user.

(578762)

**WARNING!**

Verify accessory codes. Accessory codes can be entered for photon and proton blocks, electron cutouts and proton compensators. The user must verify that the accessory code entered in RayStation matches the physical accessory to be used during treatment. RayStation will not automatically invalidate the accessory code if the block, cutout or compensator is modified in RayStation. The block, cutout or compensator will not be invalidated in RayStation if the accessory code is changed. It is the user's responsibility to ensure that the correct accessory code has been entered and, if necessary, updated.

(574934)

**WARNING!**

Ensure that the .decimal GRID block contour in RayStation matches the physical block. The CreateDotDecimalBlockContour method creates a block contour matching the .decimal GRID block. After creation, the .decimal GRID block is handled as a regular photon block in RayStation and can be edited. Since the .decimal GRID block is not manufactured based on a block contour exported from RayStation, it is crucial to ensure that the block contour in RayStation matches the physical block and that it is not unintentionally altered by manual editing. To ensure that the block contour remains unchanged, the CreateDotDecimalBlockContour method can be called again as a last step before final dose computation and plan approval.

(936115)

3.1.2 Warnings concerning installation

**WARNING!**

Display settings. Be aware that the RayStation system's visual output depends on monitor calibration, resolution and other hardware specific parameters. Ensure that the monitor output is appropriate for the clinical tasks. (366562)

**WARNING!**

Hardware/Software platform. The System Environment Acceptance Test shall be performed whenever the hardware or software platform is changed. (366563)



WARNING!

Installation tests. The user must add additional tests specific for the installation and configuration of the RayStation system at the user organization. [366564]



WARNING!

Use of non-ECC GPU memory. GPUs used for computations must have ECC RAM and the ECC state must be enabled in the GPU driver settings. Deformable image registration may however be computed on GPUs without ECC RAM.

[8453]



WARNING!

Dose calculation on GPU may be affected by computer/driver updates. The dose calculation on GPU must be revalidated after any hardware or software platform changes, including operating system Service Packs. This can be done by running the *RSL-D-RS-v2025-SEAT, RayStation v2025 System Environment Acceptance Test Protocol* and by running the self-tests for all computations using GPU.

[4039]

3.1.3 Warnings concerning general system use



WARNING!

Running multiple instances of RayStation. Take extra care when running multiple instances of RayStation. Always make sure that you are working on the correct patient.

[3312]

**WARNING!**

Independent dose calculation. Ensure that the independent dose calculation system that is used really is independent. There are systems that may appear to be suitable for independent dose calculation that are in fact not independent at all since the dose engine is manufactured by RaySearch and uses the same algorithm for photon dose computation and possibly also the same code as RayStation (e.g., Compass (IBA)).
(6669)

**WARNING!**

Be careful when changing auto recovery mode. Auto recovery data is stored in a database or on disk. If the auto recovery mode is switched off or if the storage area is changed while there is still auto recovery data in the old storage place, that data is not useful anymore and may be impossible for RayStation to delete. The data in the old storage place must be deleted manually.
(282521)

**WARNING!**

Treatment data stored in secondary databases. Do not upgrade secondary databases that hold treatment related data outside of the system connected to RayCare. These secondary databases shall remain in their current schema version.
(824240)

**WARNING!**

Report template naming. User-created report templates do not necessarily need to include all information about patient, plan, beamsets, etc. For example, a report template may only include the currently selected beam set. Use a clear naming convention when creating report templates. (5147)



WARNING!

Changed behavior for prescriptions for beam sets with background dose. From RayStation 11A, prescriptions will always prescribe dose for the current beam set. Prescriptions defined in RayStation versions prior to 11A relating to beam set + background dose are obsolete. Beam sets with such prescriptions cannot be approved and the prescription will not be included when the beam set is DICOM exported.

From RayStation 11A, prescription percentage is no longer included in exported prescription dose levels. In RayStation versions prior to 11A, the Prescription percentage defined in RayStation is included in the exported Target Prescription Dose. This has been changed in version 11A so that only the Prescribed dose defined in RayStation is exported as Target Prescription Dose. This change also affects exported nominal contributions.

In RayStation versions prior to 11A, the Dose Reference UID exported in RayStation plans was based on the SOP Instance UID of the RT Plan/RT Ion Plan. This has been changed so that different prescriptions can have the same Dose Reference UID. Because of that change, the Dose Reference UID of plans exported using RayStation versions prior to 11A has been updated so that if the plan is re-exported, a different value will be used.

[344549]

3.1.4 Warnings concerning DICOM import



WARNING!

Image set integrity. DICOM provides no way of verifying that all image slices in an image series are included. The user must always verify this manually after import. [508830]



WARNING!

Imported dose. An imported dose for an approved plan will automatically be considered clinical. [508831]

**WARNING!****For imported dose, no assumptions on how the dose was calculated are made.**

The dose will not be invalidated when data that is used for calculating dose in RayStation is different from the data the imported dose was calculated on. This applies even if the imported dose was originally calculated in RayStation. For example, if the structure set is modified with density overrides or with changes to the External ROI, the imported dose will not be invalidated.

(224134)

**WARNING!**

Fractionation scheme is discarded in DICOM import. When a DICOM plan is imported to RayStation the fractionation scheme is discarded. As a result, the beam sets created during the import will always be set for sequential delivery even if the original plan indicated an interleaved pattern.

In addition, the delivery order indicated by the beam set order may not match the intended delivery order. As a consequence, no activities that rely on a correct fractionation scheme shall be performed after the import. For example, the biological effect of the imported plan will be incorrectly reported. {119127}

**WARNING!**

DICOM import of Target Prescription Dose for proton plans. When importing a DICOM proton plan, the value imported from Target Prescription Dose {300A,0026} is interpreted in RayStation as an RBE-weighted prescription dose. {611725}

**WARNING!**

Export after using DICOM import filter. Avoid exporting data that has been modified by DICOM import filters during DICOM import. This will prevent creating different files with the same DICOM UID. {508832}



WARNING!

No error indication when using Storage SCP. There is no indication in RayStation if patient data import using Storage SCP is incomplete due to e.g., errors during the transfer session or failure with writing file to disc. [508833]



WARNING!

Review warnings when using automatic import and segmentation workflow after automatic export to another system. Warnings generated during automatic import are displayed when opening the patient for the first time. If the automatic import and segmentation workflow is used to automatically export the created structures without opening the patient in RayStation, the exported structures must be reviewed in the consuming system. Any warnings generated at import are also accessible through scripting.

[932309]

3.1.5 Warnings concerning DICOM export



WARNING!

Export failure. When exporting data from the system, always verify that the export was successful. If the export is interrupted due to e.g., hardware failure or operation systems errors, delete any exported data and restart the export. [508805]



WARNING!

DICOM RT Structure set export. The DICOM export of the RT Structure set will convert all ROIs to contours and any structure parts outside the upper or lower image set slice will not be included.

This applies to ROI geometries with mesh or voxel representation. Such geometries are typically created using model-based segmentation, atlas-based segmentation, or by using 3D ROI interaction tools in RayStation. The DICOM export only handles contours on image slices, which means that the parts that extend outside the first or last slice of the image set will not be included in the export. Thereby they will not be identical after a DICOM export/import roundtrip into RayStation or an external system. [508804]

**WARNING!**

Treatment parameters shall be transferred from the RayStation system using DICOM export. Ensure that control points for a treatment plan are exported from the RayStation system using DICOM export. The user shall not manually transfer these settings. {508803}

**WARNING!**

DICOM export of Vero plans. Extra care must be taken when DICOM exporting a plan with multiple isocenters to the Vero R&V system. It is necessary to perform the DICOM export twice, once with the ExacTrac Vero checkbox checked and once with the checkbox unchecked. {125706}

**WARNING!**

DICOM export of Target Prescription Dose for proton plans. In a DICOM-exported proton plan, the value exported to Target Prescription Dose {300A,0026} is always the RBE-weighted prescription dose. {611723}

**WARNING!**

Multi-Layer Aperture (MLA) in DICOM is communicated through private attributes. Aperture contour points when using MLA are solely exported in private attributes. For a system without knowledge of these private attributes, the fields of the treatment plan will not appear as collimated. This information is highly dosimetrically relevant and the corresponding doses will be different from that of the uncollimated plan. The user must verify that the receiving system reads the private attributes and that they are propagated to the delivery instructions for the treatment machine. Refer to the *RSL-D-RS-v2025-DCS, RayStation v2025 DICOM Conformance Statement* for more information about the private attributes. {610855}



WARNING!

Transaction errors when exporting to iDMS. If an error occurs during plan export there might be no indication in RayStation. The patient and plan state must be verified by the operator in iDMS. [261843]



WARNING!

Handling of DICOM objects with the same SOP Instance UID. In some cases, RayStation can produce DICOM objects with the same SOP Instance UIDs but with different content. If two objects with the same UIDs are sent to the same target (e.g., a PACS system), the outcome will depend on the implementation of the receiving system. The user needs to manually verify that the correct object is used for the correct task.

[404226]

3.1.6 Warnings concerning CBCT image conversion



WARNING!

External ROIs on the original image and the reference image. If the External ROI does not correspond to the patient outline in either the image to be converted or the reference image, the conversion may be incorrect. Regions outside the External ROI in the original image will not be corrected for artifacts.

[405748]



WARNING!

Field-of-view ROI for Corrected CBCT. Regions outside the field-of-view ROI are mapped from the reference image. The user must be aware that this may not correspond to the actual current geometry of the patient. If the deformable registration field is incorrect in these regions, the mapped regions will not be correct.

[405749]

**WARNING!**

Field-of-view ROI for Virtual CT. If a field-of-view ROI is used as input, mismatching low-density regions will not be replaced by values from the Corrected CBCT outside of this ROI. Therefore, it is important that the field-of-view ROI contains all the regions where this kind of replacement is potentially needed.

(405750)

**WARNING!**

Reference CT not covering the whole original image set volume. Anatomical regions in the original image that are not included in the reference CT image have insufficient information on which to base the image correction, and may therefore not be sufficiently corrected.

(405786)

**WARNING!**

Contouring on Virtual CT. The Virtual CT is created by deforming a reference CT to the original image set, followed by replacement of mismatching low-density regions. The Virtual CT will in all other regions be the same as in a deformed CT. Therefore, the geometry in the Virtual CT may not match the geometry in the original image. Contouring should preferably be performed on the original image set, or on an image converted with the Corrected CBCT algorithm.

(405815)

**WARNING!**

Material override in the reference CT. If material override is used to correct for artifacts or otherwise incorrect HU values in the reference CT, be aware that the original HU values will be used in the creation of the converted image. Consequently, the same regions in the converted image may also display incorrect intensities. The user should examine these regions and consider using material override also for the converted image.

(405752)

**WARNING!**

Image conversion algorithm commissioning. Commissioning of a conversion algorithm means that the algorithm has been deemed capable of generating clinically acceptable images. Before commissioning an algorithm, a validation of converted images generated by that algorithm shall be performed. The validation shall include dose comparison with CT images (of clinical quality), where the CT patient anatomy is as close as possible to the anatomy in the image to be converted. The impact of anatomical differences can be reduced by using images from the same day and by density override in regions with major anatomical differences. This validation must cover a sufficient number of cases of all possible imaging protocols and anatomical sites that are relevant for the imaging system.

(280182)

**WARNING!**

Approval of corrected CBCT images. When approving a corrected CBCT, make sure that the image has sufficiently good image quality to be considered adequate for clinical dose. This entails making sure that the important patient tissues have accurate HU values and that any artifacts from the original image set have been sufficiently corrected for.

If regions have been copied over from the reference CT, make sure that these appear to be correct, with a smooth transition between the regions. Major tissue HU value inaccuracies can be detected by comparing the corrected CBCT to the reference CT in the image histogram, making sure that the important tissue peaks are positioned roughly at the same value. Insufficiently corrected regions in the corrected CBCT can be identified by comparing the corrected CBCT to the deformed reference CT in the difference fusion view. All observed differences should be small or pertain to anatomical differences or noise. If there are non-negligible artifacts that have not been sufficiently corrected these regions can be handled by material overrides.

(464657)

**WARNING!**

Approval of virtual CT images. When approving a virtual CT, make sure that the image has sufficiently good image quality throughout, and that the anatomy is sufficiently close to the true anatomy in the original image set to be considered adequate for clinical dose. This mainly entails making sure that all important air/lung regions are anatomically correct in the virtual CT, and that the patient outline corresponds well with the original image set.

Comparison between the virtual CT and the original image set can be made in the fusion view using the various fusion modes. The air/lung regions in the virtual CT that have been anatomically corrected can be identified by comparing the virtual CT to the deformed reference image. Make sure that these regions correspond to real anatomy and not to severe artifacts.

(464658)

3.1.7 Warnings concerning dose computation

General dose computation warnings

**WARNING!**

Dose computation region. The dose computation region is confined to the intersection of the dose grid and the region consisting of dose computation ROIs. The dose computation ROIs include the External ROI, Support and Fixation ROIs included in the beam set, as well as Bolus ROIs assigned to external photon and electron beams. No dose will be scored in the region outside the dose computation region.

External beam therapy

For external beam therapy, all material information from image data will be omitted outside the dose computation region. For all modalities except electrons and BNCT, the volume outside of the dose computation region is treated as vacuum in the radiation transport (no interactions). For BNCT the volume outside the dose computation region is handled by the external dose computation engine.

For electrons, air is used instead of vacuum, with scattering and energy loss in the radiation transport. RayStation will not be able to compute a correct dose if any part of a beam intersects image data that is not included in the dose computation region. This could occur if the dose computation ROIs do not cover all relevant image data, or if the dose grid does not encompass the relevant volumes of the dose computation ROIs.

Large errors in dose are expected if any part of the beam enters a dose computation ROI surface which is not covered by the dose grid. An error in dose is also expected

at the exit edges of the dose grid if a too small dose grid is used, since scatter from outside the dose grid is not accounted for. There is no warning in RayStation if the dose grid does not cover the appropriate region at the exit edges.

Brachytherapy (TG43 dose engine)

The TG43 brachytherapy dose computation is a data-driven model based on measurements and simulations in water. The dose computation disregards any material information and treats the full volume as water both inside and outside the dose computation region. This has two implications with respect to the dose computation region:

- Dose on the surface of a dose computation ROI may be incorrect, since an infinite scattering medium is assumed, and the low-density interface is neglected.
- If the dose grid does not cover the entire External ROI (or any other dose computation ROI), the dose will still be correct at the edges of the dose grid, given that all active dwell points are inside the dose grid. In RayStation, it is not possible to compute dose if there are active dwell points outside of the External ROI. Inside of the External ROI, the dose grid must cover all active dwell points including at least a 3 cm margin to make sure that high dose values close to the sources are accounted for.

(9361)



WARNING!

Ensure that the correct ROI has been assigned as the External ROI. Always verify that the External ROI covers all target ROIs and OARs. Dose volume histograms might be computed erroneously if the entire ROI is not included in the External ROI.

(9360)



WARNING!

Ensure that the dose grid covers all intended ROIs. Only the part of an ROI covered by the dose grid is included in the DVH and in the dose statistics computation.

(9358)

**WARNING!**

Dose grid resolution affects dose. Both dose output and shape can be significantly affected by dose grid resolution and alignment. Make sure to use an appropriate dose grid considering factors such as e.g., field size, modulation and patient geometry.

(2305)

**WARNING!**

Pixel padding. If pixel padding is present in the region used for dose computation, the calculated dose may be incorrect. Make sure that the pixel padded Hounsfield Units map to the desired density or make sure to add a material override to the pixel padded region.

If the CT-image has excluded material which will be present at treatment and which is inside the radiation scatter region, it is not recommended to use pixel padded values. Instead, add a material override to each material to include them in the dose computation. Failure to do so might lead to errors in the dose computation.

If everything that is important for radiation transport is inside the CT-image, but the External ROI covers image parts with pixel padding values that correspond to high density Hounsfield Units, this could also lead to errors in the dose computation.

(9354)

**WARNING!**

Material override for multiple structure sets. If material override is defined for an ROI which does not have any geometry defined in the used image set, there will be no warning when computing dose.

(9353)



WARNING!

Use of CT density for non-human materials. The RayStation dose computation is tuned to be used with CT data for materials normally found within the human body. For non-human materials, using a density override will usually be more accurate than using CT data information. This applies to ROIs of type Support, Fixation and Bolus for beam structures as well as implants within the patient. Ensure that a material override has been assigned to the ROI if the CT density is intended to be overridden. No warning will be given before dose computation if no material has been assigned.

[404666]



WARNING!

Bolus ROIs need to be assigned to beam(s). Bolus ROIs are regarded as beam properties. In order for a bolus ROI to be used for radiation transport and dose computation for a certain beam, it must be assigned to that beam. If a bolus is to be used for all beams, it must be assigned to all beams individually. A bolus which is not assigned to any beam in a plan is not going to contribute to the dose computation at all.

A bolus ROI assigned to a beam will be:

- shown with solid line style in the 2D patient views,
- shown in the 3D patient view and
- included in the Material patient view when beam dose for the corresponding beam is selected.

[5347]

**WARNING!**

Ensure that all clinically relevant fixation and support ROIs are included in the beam set. By default, all Fixation and Support ROIs will be included in all beam sets. All Fixation and Support ROIs that are included in a beam set will be used for dose computation for the beam set. If a Fixation or Support ROI has been excluded from a beam set, it will be disregarded in the dose computation for that beam set.

Support and Fixation ROIs included in the beam set will be:

- marked with a blue beam set icon in the ROI list
- marked with a checked checkbox in the Fixation and support tab
- shown with solid line style in the 2D patient views
- included in the Material patient view when the beam set is selected.

[713679]

**WARNING!**

The use of ROIs of type Fixation and Support. ROIs of type Fixation and Support are intended to be used for regions with patient support, fixation or immobilization devices, and should only be used for structures that are mainly outside of the patient outline. Always use other ROI types for material override within the External ROI. A small overlap with the External ROI is acceptable if the Fixation or Support ROI is mainly outside the External ROI. The use of Fixation or Support ROIs that are mainly within the patient outline, can lead to errors in the calculation of the mass density of voxels that are intersected by both the External and the Fixation/Support ROIs. Refer to the *RSL-D-RS-v2025-REF, RayStation v2025 Reference Manual* for more details about these effects. [262427]

**WARNING!**

MR planning: Bulk density assignment. RayStation planning based only on MR images relies on the user specified bulk-density assignment. Note that for certain configurations/regions, a bulk-density assignment using a homogeneous material will produce an unacceptable dosimetric error. [254454]



WARNING!

MR planning: Geometric distortion and field-of-view. MR images intended for planning must have negligible geometric distortion. RayStation does not include any algorithm for distortion correction. The MR image should cover the patient outline. (261538)



WARNING!

Contrast enhanced CT. Contrast agents used to enhance CT image sets will affect the HU values, which can lead to differences between planned and delivered dose. The user is advised to either completely avoid using contrast enhanced CT image sets for treatment planning, or ensure that material overrides for the contrast areas are properly assigned.

(344525)



WARNING!

Ensure that doses computed with different dose engines are compatible. Combining or comparing doses computed with different dose engines (e.g., in fall-back, co-optimization, background doses, summation of doses) must be handled with care if the dose convention differs between algorithms and the plan is sensitive to dose in high Z materials.

The electron and the proton Monte Carlo dose engines report dose to water with radiation transport in medium. The proton and light ion pencil beam dose engines report dose to water. The photon collapsed cone dose engine computes dose to water with radiation transport in different density water, a property which is in between dose to water and dose to medium when computed in medium. The photon Monte Carlo dose engine for RayStation v2025 reports dose to medium with radiation transport in medium. When transported in medium, differences between dose to water and dose to medium for photons have been found to be small for tissues other than bone (1-2%), but the difference can become relatively large for bone (10%) or other high Z materials.

The dose convention for imported doses is unknown to RayStation, and should be handled with care if the plan is sensitive to dose in high Z materials and if the dose is used as background dose or for dose-mimicking.

(409909)

Electron dose computation warnings



WARNING!

Maximum allowed statistical uncertainty does not affect already computed clinical Monte Carlo dose. When changing the Maximum allowed statistical uncertainty in Clinic Settings for clinical Monte Carlo electron dose, be aware that already computed doses are not affected. Doses computed prior to the change may therefore be marked as clinical although they have a statistical uncertainty that would not result in clinical dose if they were recomputed.

[9349]



WARNING!

Electron dose calculation for small cutout sizes. Limited accuracy in calculated output for small cutout sizes has been reported for the RayStation electron dose calculation. A difference between measured and computed output of more than 3% has been reported for cutout sizes of 4x4 cm², and more than 5% for cutout sizes of 2x2 cm².

The user needs to be aware of this limitation and thoroughly verify the output of the calculated electron dose for small cutout sizes.

[142165]

Photon dose computation warnings



WARNING!

Assignment of CBCT density table. For direct usage of the raw CBCT information in dose computation, RayStation uses an image-specific CBCT density table. Since there is a limited set of density levels specified for a CBCT compared to what is normally specified for a CT, dose computation on CBCT images may be less accurate than using CT images or converted CBCT images. The accuracy of the dose computation using CBCT with an assigned density table relates to the tuning of this table, and how well the real density in the patient maps to the selected densities in the table.

Always review the density table before it is used in dose computation. The review can be performed through spot check of selected slices in the Create Density Table for CBCT dialog where the effect of the density table is visualized.

Dose calculation on raw CBCT image data sets is only supported for photons.

(9355)



WARNING!

Maximum allowed statistical uncertainty does not affect clinical status of already computed Monte Carlo dose. When changing the Maximum allowed statistical uncertainty in Clinic Settings for clinical Monte Carlo photon dose, be aware that already computed doses are not affected. Doses computed prior to the change may therefore be marked as clinical although they have a statistical uncertainty that would not result in clinical dose if they were recomputed.

(399)

**WARNING!****MR LINAC dose computation.**

Dose computation region: No dose is scored outside the dose computation region (see warning 9361). Electrons and positrons created in the dose computation region are traced in air, accounting for energy loss and magnetic field curvature, until they exit the dose grid or re-enter the patient. As it is possible that an electron/positron may be deflected outside of the dose grid but would otherwise re-enter the patient later in its path, the user must ensure that the dose grid is large enough to capture the full path of deflected electrons/positrons; otherwise, their dose contribution on re-entry to the patient will be missed. This relates to the conventional electron return effect, the lateral electron return effect and electron streaming.

Surface dose: Photon scatter in air and spiraling electrons before the patient are disregarded in the dose computation. For the Elekta Unity, this may result in a missed surface dose component in protruding surfaces in the craniocaudal direction. For the Magnetix Aurora, the electrons are confined inside the field and a conventional electron component can be added to retain surface dose to some degree. For details, refer to *RSL-D-RS-v2025-REF, RayStation v2025 Reference Manual*.

Detector selection and output factor measuring: The user must ensure to follow machine vendor measurement protocols and consult the latest scientific literature for recommended detectors, effective point of measurement shifts and magnetic field size corrections. For details, refer to *RSL-D-RS-v2025-RPHY, RayStation v2025 RayPhysics Manual*.

[1153758]

**WARNING!****Aurora MLC shadowing can lead to underdosage at off-axis y-positions.**

For Magnetix Aurora, the shadowing from the tongue extension in the tongue-and-groove region varies with y-axis position such that it may lead to a substantial decrease in dose in highly modulated plans where the tongue-and-groove region is exposed at off-axis y-positions. This variation cannot be modelled by RayStation. It is advised to fully measure and evaluate this behaviour for your specific LINAC as part of the commissioning process and ensure to keep treatment plans within the range of clinical validity. Checking plan complexity metrics, such as the relative area of exposed tongue-and-groove region off-axis, e.g. using RayStation scripting, and replanning if needed, is recommended to increase the likelihood that the plan passes plan-specific QA.

[1202498]

**WARNING!**

Asymmetry in CyberKnife Y-profiles for MLC collimated fields not accounted for in beam modeling. For the largest MLC collimated fields, the Y-profiles of the CyberKnife LINAC show an intrinsic asymmetry. This is not accounted for in beam modeling, and differences between delivered and computed doses may appear for fields collimated directly by one of the fixed Y-jaws (the side protection plates of the MLC), or by a few closed leaf pairs next to one of the Y-jaws.

The user should be aware of this limitation and be extra careful in examining this behavior in the commissioning of RayStation and in the subsequent patient-specific QA.

(344951)

**WARNING!**

Arc gantry angle spacing for rotational plans for small, off-axis targets. The arc gantry spacing determines the number of directions used during dose computation for rotational plans. Dose overestimation around 3.5% has been found for some plans with a small target that is off-axis with respect to the in-plane direction for arc beams, when using 4 degrees gantry spacing compared to using 2 degrees. The same effect is not seen for small central targets. Use a gantry angle spacing of 2 degrees when creating such arc plans.

(723988)

Brachytherapy dose computation warnings

**WARNING!**

Validity of TG43 dose calculation. The TG43 dose calculation is based on a number of assumptions: (1) all tissue around the sources are water-equivalent, (2) each source must be surrounded by a sufficiently large patient volume to keep the validity of the consensus data set, and (3) any shielding effects can be neglected. Situations when these assumed conditions are not met include: plans where the source is close to air cavities or metal implants, setups including applicator shielding and sources placed close to the skin.

The user must be aware of these assumptions and how they will affect the dose computation.

(283360)

**WARNING!**

Correctness of TG43 parameters. The accuracy of the brachytherapy TG43 dose computation is strongly dependent on the correctness of the TG43 parameters used. If available for the current source, it is strongly recommended to use published consensus data from the HEBD report (Perez-Calatayud et al., 2012) or similar reports. The resolution of the radial dose function and the anisotropy function should follow the recommendations given in the TG43u1 report (Rivard et al. 2004) and in the HEBD report. It is the responsibility of the user to verify that the TG43 parameters have been entered correctly, regardless of whether it is the user or the manufacturer that has entered the data. The user must also check the accuracy of the dose calculation algorithm using the entered parameters.

(283358)

**WARNING!**

Transit doses in brachytherapy. Doses delivered in between dwell positions, as well as entrance and exit doses from and to the afterloader, are not accounted for in the dose computation. These transit doses are dependent on the source strength and the actual movement (speed and acceleration) of the source within the HDR brachytherapy channels. The transit doses can reach clinically significant levels in some cases, especially for high source strengths, slow source movement and when the number of HDR brachytherapy channels is large, resulting in the source spending a significant portion of the time in transit. The user should be aware of this limitation and assess in which cases transit doses might become an issue for each afterloader and source.

(331758)

**WARNING!**

HDR brachytherapy delivery in magnetic fields. If the HDR brachytherapy treatment is performed in a magnetic field (e.g. delivery during MRI), there might be large discrepancies between delivered dose and dose computed using RayStation. The derivation of published TG43 parameters does not include magnetic fields and RayStation's brachytherapy Monte Carlo dose engine does not account for magnetic fields during particle transport. Any effect of magnetic fields on the dose distribution will thus be disregarded in the dose computation. The user must be aware of this limitation if the treatment is to be delivered in a magnetic field. Special care should be taken for ^{60}Co sources and for magnetic field strengths larger than 1.5 T as well for regions containing (or in close proximity to) air.

(332358)

General proton and light ion dose computation warnings

**WARNING!**

CT to density calibration for proton and light ion plans. In RayStation, the same CT to mass density calibration curve is used for proton and light ion dose calculations as for photon dose calculations. Note that the requirement on a correct CT calibration is considerably higher for proton and light ion dose calculations than for photon dose calculations. CT calibration validated for photon or electron use may not be sufficient for proton and light ion dose calculation. The same considerably higher requirements on correctness and validation of the used CT calibration for proton and light ion dose computation apply also when using a CT to Stopping power ratio (SPR) calibration curve.

(1714)

**WARNING!**

Quasi-discrete spill dose is not computed in RayStation. A quasi-discrete PBS plan is computed as a step-and-shoot PBS plan and the spill dose between spots will not be considered. The dose difference between the computed plan and the delivered plan needs to be assessed by the user in the commissioning of RayStation as well as during patient specific QA. {123711}

**WARNING!**

Dose grid effects for proton and light ion PBS plans. The Pencil Beam dose engines in RayStation calculate the average dose to a voxel along the integrated depth dose (IDD) and the dose to the center point of each voxel laterally and lets this dose value represent the dose in the entire voxel, while the RayStation Monte Carlo dose engine calculates the average dose deposited to a voxel. This means that any variation in dose that occurs on a resolution that is finer than that of the current dose grid may be lost in the dose calculation. The user has the responsibility to choose a dose grid resolution that is suitable for each plan. However, for low energy proton fields, and light ion fields without a ripple filter, the Bragg peak may be so sharp that even the highest dose grid resolution in RayStation (0.5 mm) is insufficient to resolve the Bragg peak, leading to a systematic underestimation of computed dose in relation to delivered dose. This may generate treatment plans that give a higher delivered dose than expected.

Be aware of this limitation in the dose calculation. To determine if this discrepancy is on a significant level, be extra careful in the patient-specific QA process.

(439)

**WARNING!**

Leakage between MLC leaves for protons. In the RayStation proton dose engines, a collimating MLC is regarded as an aperture block with a jagged contour, meaning that actual leakage between adjacent leaves or closed leaf tips are not handled by the dose engines. The dose difference between the computed plan and the delivered plan needs to be assessed by the user in the commissioning of RayStation as well as during patient specific QA. {371451}

**WARNING!**

Effect of non-collimating MLC leaves in dose computation for protons. In RayStation, the MLC leafs are only taken into account by the proton dose engines if the MLC is regarded as collimating. The MLC leaves are regarded as non-collimating if the MLC leaves are in their most retracted position (outside the snout inner dimension) or if the MLC leaves are positioned outside a block opening. Any effect on the dose distribution from such MLC setups are not reflected in the dose computation. The dose difference between the computed plan and the delivered plan needs to be assessed by the user in the commissioning of RayStation as well as during patient specific QA. {371452}

**WARNING!**

Closed MLC leaves may be positioned along the central axis. When automatically or manually positioning MLC leaves, the positions of closed leaf pairs are automatically set. In some cases it is not possible to place the closed leaves at the default closed leaves position defined in the machine due to other MLC leaf position restrictions. In such cases, the closed leaves might be aligned with the central axis. This might result in leakage of dose in the area where the closed leaf pair meets, which is not taken into account in the RayStation ion dose computation. It is the user's responsibility to ensure that the leaves are not closed along the central axis, or that the possible leakage is acceptable. [370014]

**WARNING!**

Snout position dependence for beam models with range modulator. A PBS beam model for protons or other light ions created with a range modulator [e.g., ripple filter and ridge filter] is defined with the range modulator in a fixed position, corresponding to the position where the beam data was obtained. If the range modulator is mounted on a movable snout, the change of range modulator position is not taken into account in the dose computation. The validity of the beam model should therefore be carefully validated for the full range of snout positions before clinical use.

[223902]

**WARNING!**

Definition of averaged LET. The user must be aware of variations in the definition of averaged linear energy transfer (LET) in the literature. Variations in the definition include, but are not limited to, whether dose-averaged or track length-averaged LET is computed, what particles are included, what medium is assumed, and the energy cutoffs used in the averaging. The specific definition affects the clinical implications of a given LET distribution, as well as its applicability to further processing such as model-based RBE dose computations. When validating LET computations, care must also be taken to ensure that what is computed corresponds to the reference data coming from measurements or independent LET computations.

A detailed description of the definition of how LET is computed and averaged in RayStation is provided in *RSL-D-RS-v2025-REF, RayStation v2025 Reference Manual*.

[406814]

**WARNING!**

Always evaluate the dose distribution when using LET evaluation. The LET distribution of a plan is an auxiliary quantity, meant to provide additional information to the primary quantity of RBE-weighted dose. The definition of averaged LET is chosen to conform to how LET is generally reported in the literature, and how it is used when estimating the biological effect using RBE models, rather than producing a directly measurable quantity.

The correlation between LET and biological effect in patients is an evolving field of science. The user must always review the literature and base the usage of LET evaluation on the current state of knowledge in the field and clinic-specific treatment techniques and modalities.

(408388)

**WARNING!**

Statistical uncertainty does not apply to computed beam LET distribution. The reported statistical uncertainty for Monte Carlo proton beam doses only applies to the dose distribution and not to the LET distribution.

(406166)

Proton US/SS/DS/Wobbling dose computation warnings

**WARNING!**

US/SS/DS/Wobbling beam monitor units. The beam monitor units value in RayStation is not expected to be dosimetrically correct and shall only be used as a means to control the dose level displayed in RayStation. (370010)

**WARNING!**

Anisotropic lateral beam spread for US/SS/DS/Wobbling. RayStation does not consider anisotropic lateral scattering in the dose calculation of Uniform Scanning, Single Scattering, Double Scattering or Wobbling beams. In the dose engine validation of the Sumitomo Wobbling delivery system, it was found that the error in lateral penumbra is significant (> 2 mm for 80%-20% penumbra width) for fields using the largest fixed field size setting of the treatment machine and an aperture with a physical opening of 15 cm in combination with a large air gap (25 cm).

Be aware of this limitation in the dose calculation and be extra careful in the patient specific QA process for fields that employ a combination of large field sizes and large air gaps. (261663)

**WARNING!**

Accuracy of Pencil Beam dose engine for proton US/SS/DS/Wobbling beams with thick beam line components. In the RayStation US/SS/DS/Wobbling pencil beam dose engine validation, a few deviations from the dose accuracy requirements were noted for doses in water, especially at shallow depths, for setups where the protons pass through a thick beam-line component (e.g. range shifter, range modulator, or compensator). These deviations have been linked to the handling of secondary proton transport over the air gap, resulting mainly in an overestimation of the dose in the surface region. The effect increases with thickness of the component. When a compensator is used, the effect is larger for increasing air gaps. For components mounted in the non-moveable part of the nozzle, the effect is not primarily dependent on the air gap.

The user shall be aware of these limitations in the pencil beam dose engine, and is recommended to minimize the air gap when a compensator is used. (370009)

**WARNING!**

Aperture edge scatter effect for SS/DS/US/Wobbling. Scatter from the edges of the MLC and block aperture is not included in the RayStation US/SS/DS/Wobbling proton dose calculation algorithm.

The effect of the edge scatter is to add characteristic "ears" to the edges of the lateral dose profiles. These "ears" are most pronounced in the surface region but may also affect the dose deeper into the patient as well as the shape of a central axis depth dose curve. The shape and magnitude of the edge scatter "ears" depend on factors such as:

- The depth of the measured profiles. The "ears" are sharper at shallow depths and get more diffused at greater depths, to eventually disappear at some distal depth.
- The air gap. The "ears" get more diffused for larger air gaps.
- The field size. More edge scatter is expected for larger fields, since more of the inner aperture edge is exposed to the beam.

The effect of the omission of the edge scatter in the dose calculation can lead to discrepancies between delivered and computed dose, especially in the surface region, and sometimes deeper into the patient.

Be aware of this limitation in the dose calculation and be extra careful in the patient specific QA process to be able to determine if the omission of the edge scatter in the dose calculation is acceptable or not for each individual patient case.

(261664)

**WARNING!**

Apertures mounted downstream of the compensator for US/SS/DS/Wobbling. In the RayStation proton dose engine for delivery systems where the aperture is mounted downstream of the range compensator, there is an algorithm intended for reproducing the sharpening effect of the lateral dose penumbra that this setup provides. An artifact of this algorithm is that the scattering caused by the range compensator in the central parts of the field (away from the aperture edge) is underestimated. This artifact can give significant errors in the computed dose for compensator geometries that host large gradients in the interior of the compensator. A more detailed description of this artifact is given in the *RSL-D-RS-v2025-REF, RayStation v2025 Reference Manual*.

Be aware of this limitation in the dose calculation and be extra careful in the patient specific QA process for delivery systems where the aperture is mounted downstream of the range compensator. (150310)



WARNING!

Surface dose overestimation for Wobbling. A systematic overestimation of the computed dose in the surface region has been found for a few beam configurations of the Sumitomo Wobbling delivery system. The error may become significant for beam configurations that combine a high beam energy with a large modulation ridge filter and a thick compensator. The error becomes more pronounced for large field sizes, although the effect is also present for smaller field sizes.

Be aware of this limitation in the dose calculation and be extra careful in the patient specific QA process for fields that involve a combination of high beam energy, large modulation ridge filter and a thick compensator. {261665}



WARNING!

Flat fluence for US/SS/DS/Wobbling. The RayStation US/SS/DS/Wobbling pencil beam proton dose calculation algorithm assumes a flat fluence unless a radial fluence correction is explicitly defined. It is the user's responsibility to decide whether the flat fluence assumption is acceptable for their delivery system or if radial fluence correction curves for the beam model should be provided.

{372132}



WARNING!

Lateral penumbra at large air gap for US/SS/DS/Wobbling. The lateral penumbra is sometimes significantly underestimated at shallow depths and in a few cases overestimated at the end of the SOB range for beams with a large air gap between the aperture and the patient. This effect has primarily been observed for beams with a thick range shifter and/or a range modulator with a high-Z material.

The user shall be aware of this limitation in the pencil beam dose algorithm and is recommended to always minimize the air gap for US/SS/DS/Wobbling beams. {372143}

**WARNING!**

The effect of the infinite slab approximation on proton US/SS/DS/Wobbling. The US/SS/DS/Wobbling Pencil Beam dose engine is based on the so-called infinite slab approximation. This approximation disregards lateral inhomogeneities for individual ray traces, which will see the patient as a stack of semi-infinite layers. The effect of this approximation is more severe for patients with large lateral inhomogeneities, especially closer to the target area. This situation is common for many lung cases with the effect of significant loss of target coverage. It should be noted that also other treatment sites may be affected.

Be aware that the dose computation may not be accurate for patients with large lateral inhomogeneities relative the beam direction. {370003}

**WARNING!**

Range compensator effect in proton US/SS/DS/Wobbling Pencil Beam dose calculation. The proton US/SS/DS/Wobbling Pencil Beam dose engine treats any range compensator device as an extension of the patient and the pencil beam tracing will start at the entrance of the range compensator. This means that the broadening of each pencil beam ray trace may have become significant when reaching the patient surface and the dose error caused by the infinite slab approximation in the presence of any lateral inhomogeneity may be large. It is important to point out that the patient outline here becomes a large lateral inhomogeneity when it is angled to the ray traces. This error will thus increase with:

- Magnitude of air gap
- Angle between beam and surface normal
- Shallowness of target
- Internal lateral inhomogeneities

The user shall be aware of this limitation in the pencil beam dose engine. {383008}

**WARNING!**

Patient-specific calibration of meterset rate for US/SS/DS/Wobbling. The setup used in the patient-specific calibration of beam meterset rate for US/SS/DS/Wobbling beams should be as close as possible to the treatment plan setup. {522820}



WARNING!

Overestimation of entrance dose for Mitsubishi Electric Co SELECT BEAM NOZZLE in US mode. A systematic overestimation of the computed dose in the entrance region has been found in the dose engine validation for a significant fraction of US beam delivered by the Mitsubishi Electric Co SELECT BEAM NOZZLE in US mode. The error becomes significant for beams employing a range shifter thickness that is significantly larger than the minimum range shifter thickness defined for the present Range Option (Beam Data). The error becomes larger if a range compensator is added to the beam. The error caused by the range shifter is only weakly dependent on the snout position, while the surface dose error caused by the range shifter increases with increasing air gap between compensator and patient.

This error in dose is linked to the handling of secondary proton transport over the air gap, resulting mainly in an overestimation of the dose in the surface region.

The user shall be aware of these limitations in the pencil beam dose engine, and has the responsibility to ensure that a sufficient number of Range Options (Beam datas) with offset range shifter thicknesses are included in the system/beam model.
(382252)

**WARNING!**

Lateral penumbra for beams using block aperture in combination with compensator for Mitsubishi Electric Co SELECT BEAM NOZZLE in US mode. In the dose engine validation of RayStation v2025, a systematic deviation has been found in the computed lateral dose for beams delivered with the Mitsubishi SELECT BEAM NOZZLE in US mode (Mitsubishi US) using a block aperture in combination with a range compensator. The studied fields used an 8x8 cm² squared block aperture opening in combination with a 3 cm or 6 cm homogeneously thick range compensator, and were delivered to a water phantom. The measured lateral profiles exhibit more rounded shoulders (high dose field edges) than observed in the calculated profiles, while the low dose part of the calculated profiles (dose levels < 50%) is in excellent agreement with the measurements. Consequently, the calculated profiles can be significantly broader than the measured profiles at for example the D95% level, and the difference in 20-80% lateral penumbra has been observed to exceed 2 mm in several cases. The fail rate in Gamma (3 mm, 3%) analysis of the profiles, has also been seen to exceed 5% relatively frequently.

These deviations were not found for Mitsubishi US fields employing the MLC as primary collimator or for fields that used a block aperture without a range compensator.

Refer to *RSL-D-RS-v2025-REF, RayStation v2025 Reference Manual* for more details.

Be aware of this limitation in the pencil beam dose engine and be extra careful in examining this behavior in the commissioning of RayStation and in the subsequent patient-specific QA.

[1657]

**WARNING!**

Dose accuracy for the Optivus double scattering system. In the RaySearch dose engine validation it was discovered that the shoulders of lateral dose profiles are not always accurately reproduced in RayStation. This results in the failure of the dose accuracy requirement: Gamma (3%, 3 mm) passing rate > 95%. For these fails, the computed curves exhibit rounder shoulders than the measured profiles, which results in for example an underestimation of the width of the field at D95%. The effect is most pronounced for shallow and mid depths of large fields (> 10 cm) at the higher energies.

Be aware of this limitation in the dose calculation and be extra careful in the patient specific QA process to be able to determine if this deficiency is acceptable or not for each individual patient case.

[410850]

**WARNING!**

Dose deviation at depths <10 mm for small, shallow proton SS/DS/US/Wobbling beams. In the RaySearch analytical SS/DS/US/Wobbling dose engine validation of ocular proton therapy treatment fields, it was discovered that the shoulders of the lateral dose profiles are not always accurately reproduced at depths <10 mm. This deviation was traced to the generation of low energy protons that are created by a range-verifying system in the treatment nozzle of the delivery system used for validation. These protons are unevenly spread across the aperture opening, which is not supported in the analytical RayStation dose engine. The dose engine assumes that the protons in a field have a lateral fluence independent of energy.

The user shall be aware that the dose at shallow depth may be affected by a range-verifier.

{581160}

Proton PBS dose computation warnings

**WARNING!**

Accuracy of Pencil Beam dose engine for proton PBS and Line Scanning beams with range shifters. In the RayStation PBS Pencil Beam dose engine validation, a few deviations from the dose accuracy requirements were noted for doses in water, especially at shallow depth, when a range shifter with a relatively large air gap was used. These deviations have been linked to the handling of secondary proton transport over the air gap, resulting mainly in an overestimation of the dose in the surface region, but the spot to sub-spot discretization may also contribute to the dose error when spots at the patient surface become very large.

The user shall be aware of these limitations in the pencil beam dose engine. It is strongly recommended to use the RayStation Monte-Carlo dose engine for computation of final dose for any beam including a range shifter. {36952?}

**WARNING!**

Sub-spot limitations for Proton PBS PB dose engine. In the RayStation PBS pencil beam dose calculation, the Gaussian spot fluence is discretized into 19 sub-spots. This is done to minimize the errors introduced by the inherent infinite slab approximation of the pencil beam algorithm. The choice of 19 is a compromise between the accurate representation of the initial Gaussian fluence and the sufficiently course sampling of the patient geometry for typical spot sizes on the one hand, and the calculation speed on the other.

The distance between the sub-spots in the proton Pencil Beam PBS dose engine is dependent on the spot size. The sub-spot distance is around 85% of the spot size (spot sigma), which for a 5 mm spot results in a sub-spot distance of around 4 mm. When the spot size gets very large, the distance between the sub-spots may be larger than the geometrical variations of the patient, which then will not be taken into account by the Pencil Beam dose engine. For spots that are glancing the patient surface (for example from tangential beams) only the sub-spots that intersect the patient geometry (External ROI) will be taken into account. As a consequence, there is a potential loss of dose in the surface region. Large spot sizes are for example common when a range shifter with a large air gap is used in combination with low beam energies.

Refer to *RSL-D-RS-v2025-REF, RayStation v2025 Reference Manual* for more details.

The user shall be aware of this limitation in the PBS dose calculation and it is strongly recommended to use the RayStation Monte-Carlo dose engine for computation of final dose for any beam including a range shifter. {369528}

**WARNING!**

Scanned field size limitations for Proton PBS PB dose engine. The PBS Pencil Beam dose engine validation of RayStation only covers scanned field sizes down to 4 x 4 cm². Be extra careful when creating PBS and Line Scanning plans with scanned field sizes smaller than 4 x 4 cm². {369529}

**WARNING!**

Too high spot weights outside block and MLC aperture contour. Be aware that too high spot weights outside the aperture contour could lead to mistreatment if the aperture is misaligned in the machine or if the aperture is unintentionally left out during treatment. {252691}



WARNING!

Robust optimization in combination with PBS block and MLC apertures. If robust optimization is used in combination with a static aperture for proton PBS plans, make sure that the aperture margins are large enough (they should also include the position uncertainty) so that the resulting plan is robust. (252705)



WARNING!

Field size limitations for Proton PBS MC dose engine. The Monte Carlo PBS dose engine validation of RayStation only covers the following setups related to field size:

- Scanned field sizes down to 4 x 4 cm²
- MLC aperture openings down to 2 x 2 cm²
- Block aperture openings down to 4 x 4 cm²
- Block aperture openings with diameters between 8 and 15 mm for shallow fields with ranges between 5 and 30 mm

Be extra careful when creating PBS and Line Scanning plans with scanned field sizes or aperture openings smaller than the setups covered in the dose engine validation.

(369532)

**WARNING!**

Dose accuracy for the proton MC dose engine used for small shallow fields. The Monte Carlo PBS dose engine validation of RayStation shows some deviations from the dose accuracy requirements when compared with measurements for small shallow fields. The validation includes fields with depth ranging from 5 to 30 mm, using aperture openings with diameters of 8 and 15 mm. The treatment nozzle used in the test setup has a range shifter that is placed 72 cm upstream of the aperture. For these setups, the accuracy requirements are a gamma (3%,0.3mm) pass rate above 90% and a gamma (5%,0.5mm) pass rate above 95%. For the test cases using an 8 mm aperture diameter, the RayStation Monte Carlo PBS dose engine tends to overestimate the dose relative to measurements, and in one case the validation fails the gamma (3%,0.3mm) accuracy requirement, with a fail rate of about 14%. Test cases for an equivalent setup but with a 15 mm aperture diameter pass all accuracy requirements, and all test cases for small shallow fields pass the gamma (5%,0.5mm) requirement.

The user is advised to be extra careful when creating plans with aperture openings smaller than 15 mm.

{82440?}

**WARNING!**

The effect of the infinite slab approximation in the PB dose engine on proton PBS/Line Scanning. The proton PBS/Line Scanning Pencil Beam dose engine is based on the so-called infinite slab approximation. This approximation disregards lateral inhomogeneities for individual ray traces, which will see the patient as a stack of semi-infinite layers. The effect of this approximation is more severe for patients with large lateral inhomogeneities, especially closer to the target area. This situation is common for many lung cases, but other treatment sites may also be affected. For lung cases with range shifters, dose to tumors in lung tissue has been shown to be overestimated by up to 10% in the PTV center, with significant loss of target coverage even after dose rescaling.

Be aware that the dose computation may not be accurate for patients with large lateral inhomogeneities relative the beam direction. It is strongly recommended to use the RayStation Monte Carlo dose engine for computation of final dose for any patient where the beam will see large lateral inhomogeneities. {369533}

**WARNING!**

Mevion Spot Map Converter (SMC) is used for Mevion Hyperscan. During final dose computation with the Ion Monte Carlo dose engine, beam data such as energy layer details, spot positions, spot MU, number of paintings and collimator contour is passed through the Mevion Spot Map Converter (SMC) which optimizes spot delivery and individual pulse collimation. The output from the SMC is then used during dose computation in order to include the actual positions of the collimator leaves for each spot. However, the dose calculated in the optimization uses the SMC output based on the initial spot pattern. The difference of the initial and final spot pattern may result in a difference between the optimized non-clinical dose and the final clinical dose.

Refer to *RSL-D-RS-v2025-REF, RayStation v2025 Reference Manual* for more details. (369117)

**WARNING!**

Dose validation off-axis for Mevion Hyperscan. The dose validation for Mevion Hyperscan shows significant discrepancies for plans with spots at a distance to the isocenter larger than 7 cm in X or Y. These discrepancies are believed to be effects from irregularities in the treatment delivery across the field, where the delivered spot meterset is higher than what is intended in the plan. This effect increases gradually towards the maximum distance to isocenter of 10 cm in X and Y, reaching a maximum of about 3% in the difference between planned and delivered spot metersets. If the peripheral spots have a relatively higher meterset, the corresponding deviation in dose may be even larger. This effect has been confirmed by Mevion Medical Systems.

This issue has been addressed by Mevion Medical Systems and a lateral spot meterset correction is available for Hyperscan machines. Users must implement this correction or take extra care when setting up off-axis fields.

(300)

**WARNING!**

Dose accuracy for the proton MC dose engine used with Mevion Hyperscan. The Monte Carlo PBS dose engine validation for Mevion Hyperscan shows deviations from the dose accuracy requirements when comparing to measurements for the following cases:

- Absolute dose for small targets

The dose engine validation for Mevion Hyperscan shows a significant deviation (above 3%) in absolute dose for cube targets of size $3 \times 3 \times 3 \text{ cm}^3$ at different depths, and for single-energy scanned fields with lateral size $4 \times 4 \text{ cm}^2$. The deviation becomes larger for larger air gaps.

- Absolute dose at edge-of-field when using apertures

The dose engine validation for Mevion Hyperscan shows that RayStation significantly overestimates the dose at the field edges. The difference is most pronounced near the surface and when using an aperture.

Be extra careful when creating PBS plans for Mevion Hyperscan in cases where one of the above identified deviations can be clinically significant. {384587}

**WARNING!**

Maximum allowed statistical uncertainty does not affect already computed clinical Monte Carlo dose for protons. When changing the Maximum allowed statistical uncertainty for clinical Monte Carlo proton dose, be aware that already computed doses are not affected. Doses computed prior to the change may therefore be marked as clinical although they have a statistical uncertainty that should not result in clinical dose if they were recomputed. {369534}

Light ion PBS dose computation warnings

**WARNING!**

The effect of the infinite slab approximation on light ion PBS. This approximation, inherent to the pencil beam algorithm, disregards lateral inhomogeneities for individual ray traces, for which the patient is seen as a stack of semi-infinite layers. The user shall therefore be aware that the dose computations may not be fully accurate for patients with large lateral inhomogeneities relative to the beam direction.

{461}

**WARNING!**

Field size limitations for carbon ion PBS. The dose engine validation of RayStation covers field sizes between $3 \times 3 \text{ cm}^2$ and $20 \times 20 \text{ cm}^2$. Be extra careful when creating fields with field sizes that are smaller or larger than these field size limits.

(6483)

**WARNING!**

Field size limitations for helium ion PBS. The dose engine validation of RayStation covers field sizes between $3 \times 3 \text{ cm}^2$ and $20 \times 20 \text{ cm}^2$. Be extra careful when creating fields with field sizes that are smaller or larger than these field size limits.

(219201)

**WARNING!**

Limitations of the pencil beam algorithm. The pencil beam algorithm employed for light ion dose computation entails certain approximations and limitations. These may affect the accuracy of the computed dose in voxels at the surface of the patient, especially in the presence of a range shifter and/or tangential beams. This includes doses computed for spots that do not intersect the patient at all, such as may occur in certain robust optimization scenarios, as well as for spots with a Bragg Peak in the range shifter.

(1311597)

**WARNING!**

Absolute dose accuracy for helium ion PBS with range shifters. There are limitations to the modeling of the beam spread in the region between a range shifter and the patient, also called the air gap, in the analytical dose engine used for helium ion dose calculation in RayStation. The dose engine has been successfully validated for air gaps up to 40 cm, while for larger air gaps discrepancies have been observed, especially for small fields and/or thick range shifters. The user is therefore encouraged to be extra careful when using air gaps larger than 40 cm.

(219202)

**WARNING!**

Dose-averaged LET accuracy for light ion PBS in materials substantially different to water. The analytical dose engine used for light ion dose calculation in RayStation has known limitations in the description of nuclear interactions for materials substantially different to water, for example bone and lung tissue. If the beam traverses through materials heavier than water, RayStation will underestimate the dose-averaged LET, whereas it will overestimate it for materials lighter than water. In most clinical cases, where a beam passes through different kinds of materials, these effects will cancel out and the deviation is small, typically below 1%. However, if the beam traverses a significant distance through such material the effect may become more significant. In such cases the accuracy of the dose-averaged LET calculation will be affected. The user is encouraged to be extra careful when a beam traverses a significant distance through materials substantially different to water.

(410378)

**WARNING!**

Clinical practices related to RBE models. The user is expected to be well informed of the relevant clinical practices that relate to the models for predicting relative biological effectiveness (RBE) and to closely follow published literature on the subject. This includes awareness of the uncertainties involved and the difficulty in directly measuring RBE-weighted dose. (261621)

**WARNING!**

Limitations in RBE-weighted dose and dose-averaged LET computation. The primary and secondary particle energy spectra used in RBE-weighted dose and dose-averaged LET calculation were simulated in water. The user should be aware of this limitation and its potential effect on RBE-weighted dose and dose-averaged LET in heterogeneous regions, and primarily in materials that differ significantly from water.

(5133)

**WARNING!**

Limitations in RBE-weighted dose and dose averaged LET computation. The prediction of RBE-weighted dose and dose averaged LET is dependent on the mixed radiation field at each position. In RayStation, this is quantified by simulated primary and secondary particle energy spectra. Differences and uncertainties in the particle energy spectra are propagated to the dose computation in addition to the inherent uncertainties of the biological model used to calculate the RBE.

The user should be aware of the sensitivity to the input particle energy spectra in the prediction of RBE-weighted dose and dose-averaged LET.

(2222)

**WARNING!**

Accuracy of dose-averaged LET calculation for sharp peaks. The dose-averaged LET calculation for light ions in RayStation has limited accuracy when describing peaks with widths on the order of one millimeter, and RayStation may underestimate the value. An example is the steeply peaked dose-averaged LET from a single Bragg Peak. The user is encouraged to be extra careful when evaluating dose-averaged LET for such sharp features.

(410376)

**WARNING!**

Limitations of the nuclear interaction correction (NIC). The inelastic nuclear interaction cross section model used in the NIC algorithm is valid for all projectiles and targets with atomic number less than or equal to 26. Be extra careful when planning a light ion beam traversing materials that contain a significant mass fraction of atoms with atomic number greater than 26.

(719383)

**WARNING!**

Approximate lateral dependence of the mixed radiation field for RBE weighted dose and dose-averaged LET. The lateral fluence distribution of primary particles and fragments is computed using a trichrome approximation. The trichrome approximation makes use of the MCS and nuclear halo gaussians and associates them with different particle species to achieve realistic lateral distributions of the fluence of primaries and fragments. The approximation can cause significant errors in areas of the field where the distribution of primary particles and fragments is different to where there is a lateral equilibrium in the mixed radiation field, for example, outside of the field, within a small field, or at the edge of a larger field. Note that the effect is directly visible in the dose-averaged LET, but contributes only as a secondary effect for the RBE.

(408315)

**WARNING!**

Limitations in the LEM model for high doses. Due to the limited availability of experimental data for high fraction doses, the Local Effect Model (LEM) has not been comprehensively evaluated and the user should be aware that the model may be unreliable at high fraction doses. (261598)

**WARNING!**

Variations in RBE for different LET values using LEM-I. It has been observed that LEM-I tends to overestimate the RBE at low Linear Energy Transfer (LET) values, and underestimate the RBE at high LET. From a clinical point of view for the carbon modality, these trends go in the "right" direction in the sense that the actual effect in normal tissue located in the entrance channel should be lower than predicted by the model, whereas the effect in the tumor region should be higher than predicted. However, for the helium modality, these effects make LEM-I unsuitable for clinical use. The user should be aware of these effects.

(458)

**WARNING!**

The s_{\max} parameter of the Low Dose approximation. In the computation of RBE in the Low Dose approximation of LEM, the slope at the transition to exponential dose-effect relation at high doses is represented by the parameter s_{\max} . This can either be taken to be the slope of the reference radiation curve or of the ion radiation curve. The RayStation implementation follows the latter choice, while other implementations, such as TRiP, follow the former. The effect of this difference in the approximation is in general very small and only relevant for high doses. Although the low-dose approximation cannot be used to calculate clinical dose, the user should be aware of this difference.

(221231)

**WARNING!**

Number of repetitions for LEM Classic. When calculating RBE-weighted dose according to the LEM model, it is required to use at least 1000 repetitions in the LEM Classic algorithm to obtain a clinical dose in RayStation. It should be noted that more than 1000 repetitions may be required to obtain sufficient statistical accuracy. The necessary number of repetitions is dependent on modality, model parameters and fragment spectra. It is the responsibility of the user to ensure that the statistical accuracy from the LEM Classic dose computation is sufficient.

(221247)

**WARNING!**

Track dose parameter limitations for RBE using LEM-I. The RBE-weighted dose according to LEM-I has only been validated using the following track dose parameters:

- Track core radius = 0.01 μm
- Prefactor $\{\gamma\} = 0.05 \mu\text{m} \{\text{MeV/u}\} \cdot \delta$
- Exponent $\{\delta\} = 1.7$
- No Kiefer low energy approximation

Although it is possible to choose different parameters as input to RayStation, this should be handled with extra care as it lies outside the bounds of the current clinical use of the Local Effect Model.

(459)

**WARNING!**

Cell type parameter limitations for RBE using LEM-I. The RBE-weighted dose according to LEM-I has been validated for the carbon modality using a range of cell types with varying radio sensitivity. The user is expected to closely follow published literature with regard to which cell type parameters are suitable for clinical use. The choice of parameters to be used for clinical purposes should be made based on an extensive evaluation of the safety and the clinical efficacy.

(457)

**WARNING!**

Cell type parameter limitations for RBE based on LEM-IV. The RBE-weighted dose according to LEM-IV has been validated for the helium modality using the following two sets of cell type parameters:

set 1

- $\alpha_x = 0.10 \text{ Gy}^{-1}$
- $\beta_x = 0.050 \text{ Gy}^{-2}$
- $D_t = 8.0 \text{ Gy}$
- $r_n = 5.0 \mu\text{m}$

set 2

- $\alpha_x = 0.50 \text{ Gy}^{-1}$
- $\beta_x = 0.050 \text{ Gy}^{-2}$
- $D_t = 14 \text{ Gy}$
- $r_n = 5.0 \mu\text{m}$

These parameters have never been used in clinical practice, and extensive evaluation of safety and clinical efficacy needs to be carried out before they are applied for clinical purposes.

Extra care should also be taken if using a different set of cell type parameters.

(219180)

**WARNING!**

Dose calculation parameter limitations for RBE using MKM. The RBE-weighted dose according to MKM has only been validated for the carbon ion modality using the following dose calculation parameters:

- Clinical scale factor = 2.41
- Reference radiation $\alpha_r = 0.764 \text{ Gy}^{-1}$
- Reference radiation $\beta_r = 0.0615 \text{ Gy}^{-2}$

Extra care should be taken if using plans for other modalities than the carbon ion modality.

Although it is possible to choose different parameters as input to RayStation, this should be handled with extra care as it lies outside the bounds of the validation scope.

[66531]

**WARNING!**

Cell type parameter limitations for RBE using MKM. The RBE-weighted dose according to MKM has only been validated for a single cell type with fixed radio sensitivity using plans for the carbon ion modality. The following cell type parameters apply, i.e., HSG:

- $\alpha_0 = 0.1720 \text{ Gy}^{-1}$
- $\beta = 0.0615 \text{ Gy}^{-2}$
- $r_d = 0.32 \mu\text{m}$
- $r_n = 3.9 \mu\text{m}$

Extra care should be taken if using plans for other modalities than the carbon ion modality.

Although other cell type parameters can be imported to the model in RayStation, users should not apply this for clinical purposes until an extensive evaluation of the safety and the clinical efficacy has been carried out.

[66530]

**WARNING!**

User-defined RBE models. When RBE cell type parameters and data tables are imported to a user-defined RBE model, the user has the full responsibility to ensure the validity and clinical applicability of this data before the RBE model is commissioned. There is no validation of the imported data performed in RayStation. (262079)

**WARNING!**

Comparison of RBE-weighted dose calculated with different RBE models. RayStation supports different approaches to the calculation of the RBE. While each approach gives an RBE-weighted dose (in units Gy(RBE)), it is important to note that the doses are not directly comparable in terms of absolute values, and any comparison of results using different RBE models must be done very carefully. (67927)

BNCT dose computation warnings

**WARNING!**

RBE model Standard BNCT. The user has the full responsibility to ensure the validity and clinical applicability of the parameters used for the cell types before the RBE model is commissioned. (611936)

**WARNING!**

Boron concentration. The dose is calculated based on a boron distribution according to the cell type to blood boron concentration defined in the RBE model and the planned blood boron concentration. The user shall be aware of that if the boron concentration is significantly different in the patient compared to what was used in the plan, the dose delivered to the patient will deviate significantly from the calculated dose. (611940)

**WARNING!**

Material rescaling approximation for cell type dose computation. The rescaling of the physical dose components employed in the standard BNCT RBE cell type dose computation to account for different materials is an approximation of a full dose computation. Large differences between the material for which the cell type dose computation is performed and the original material assigned to the voxel may therefore affect this approximation. The user must be aware of this approximation and its limitations when evaluating cell type doses or quantities computed from them (such as DVHs, clinical goals, dose statistics and prescriptions). See section *Cell type dose computation* in the *RSL-D-RS-v2025-REF, RayStation v2025 Reference Manual* for further details.

1201180

3.1.8 Warnings concerning patient modeling

**WARNING!**

Automatic ROI generation and modification. Always verify the outcome of automatic ROI generation and modification. Special attention should be given to choosing the appropriate organ model for the patient based on characteristic model properties such as body region, patient position, and image modality. This applies to all automatic segmentation methods including model-based segmentation, atlas-based segmentation, and deep learning segmentation.

For deep learning models, the model data sheet must be reviewed prior to applying the model clinically, as important limitations and usage information are listed there.

Note that no automatic organ segmentation may be used to identify lesions in RayStation.

(9662)

**WARNING!**

Automatic image registration. Always verify the outcome of automatic image registration.

(9660)

**WARNING!**

Modifying imported POIs intended for treatment position alignment. Modifying imported POIs intended for treatment position alignment with types 'Acquisition isocenter' and 'Initial match isocenter' before performing 'CBCT treatment position alignment' will result in an erroneous alignment.

(9653)

**WARNING!**

Image set slice spacing and extrapolation of contours. In RayStation, the 3D reconstruction of an ROI from contours assumes that the first and last contours extend half a slice distance. The first and last contours of an ROI are therefore extrapolated half a slice distance from the outermost drawn contours. Note that there is no limit for this extrapolation, it is always half a slice distance. For typical image sets with a slice distance of about 2-3 mm this means that RayStation extrapolates 1-1.5 mm, but in an image set with wide slice spacing, this extrapolation may lead to unexpected behavior. It is therefore highly recommended to always use planning CTs reconstructed with a slice spacing less than or equal to 3 mm.

(9492)

**WARNING!**

Missing intermediate ROI contours. If there are missing intermediate ROI contours, the gap is NOT filled in automatically.

If there are image slices with missing contours between the outermost contours of the ROI geometry, no automatic interpolation is performed between the contours. This applies to imported contours as well as contours generated in RayStation.

(9658)

**WARNING!**

ROI geometry extending outside the image set. When performing a contour operation (e.g., manual drawing, simplify contours etc.) on an ROI that extends outside the top or bottom of the image set, the ROI will be cut at the top and bottom slices of the image set.

(8817)



WARNING!

Review the deformable registration. Always review the deformable registration before it is used to deform dose by:

- evaluating the registration in the Fusion view.
- evaluating the deformed grid in the Deformed grid view.
- evaluating mapped structures between reference and target image sets.

This is especially important for dose tracking and when deformed dose is used as background dose during optimization of an adapted plan. Note that biomechanical deformable registrations are not guaranteed to be invertible and should therefore be evaluated extra thoroughly.

[9656]



WARNING!

Review the accuracy of mapped structures. Before mapped structures are used for treatment planning or evaluation purposes, make sure to always review the accuracy of structures mapped between image sets using deformable registrations. Note that biomechanical deformable registrations are not guaranteed to be invertible and should therefore be evaluated extra thoroughly.

[9651]



WARNING!

Create common material with new elemental composition. It is possible to define a material which does not reflect a physically reasonable material with respect to the combination of mass density and elemental composition. Be careful with the order of atomic numbers and weights to make sure that both have the same order. The dose engines in RayStation are optimized for materials similar to those found in the human body. Using materials outside that domain may decrease the dose accuracy.

[274572]

3.1.9 Warnings concerning treatment planning



WARNING!

Collision avoidance: Always verify patient position, gantry angles and couch angles (or ring angles for machines where couch rotation is replaced by ring rotation). The patient/machine setup must be manually verified for all beams to avoid collisions causing patient injury or equipment damage. The Room view shall not be used to verify that no collisions will occur with current patient/machine set up. For TomoTherapy treatments, see also warning 254787 (**Collision avoidance for TomoHelical and TomoDirect**).

[3310]



WARNING!

Images in upright scanning position typically labeled as HFS. Due to the limitations of the DICOM standard, images acquired in the upright scanning position are typically labeled as head-first supine (HFS). The 'SITTING' scanning position does not exist in DICOM. For images acquired by CT scanners that provide the backrest pitch angle, this angle will be shown in the RayStation GUI as a suffix appended to the patient scanning position.

[1201906]



WARNING!

Select correct treatment position. Make sure that the correct treatment position (head first/feet first) is selected for the patient when creating a treatment plan. The selected treatment position will affect how beams are oriented relative to the patient. Incorrect specification may lead to mistreatment of the patient.

Note that a treatment position different from the patient position in the CT data (patient scanning position) can be selected when a plan is created. Only use this option if the patient is to be treated in a different position than he/she was positioned in during scanning. [508900]

**WARNING!**

Collimator angle for VMAT, Conformal Arc and Static Arc. Collimator angles 0, 90, 180 and 270 degrees should if possible be avoided for arc beams as these may lead to accumulated dose leakage. The collimator angles should preferably be shifted at least 10 degrees from the above values. The accumulated dose leakage due to interleaf transmission is not reproduced by the clinical dose computation. Be aware of this when making clinical decisions. Closed leaf pairs are likely to be positioned in the middle of the target projection which may accumulate the leakage to the center of the target at these collimator angles.

(3305)

**WARNING!**

Computing dose for small structures. When using small structures it is important to be aware of that they may be significantly affected by discretization effects. It is therefore important to choose dose grid resolution based on the smallest structures that need to be reconstructed. When structures are reconstructed for visualization in patient views, a structure-specific high-resolution grid is used in order to represent the structure accurately. However, for plan optimization, dose computation and dose statistics, the structures are reconstructed on the dose grid. If the dose grid voxels are too large, the reconstruction may represent the structures inaccurately. Furthermore, there will be a discrepancy between the visualized structures and what is actually used for dose computations. It is therefore highly recommended to use a dose grid resolution such that the size of one dose grid voxel does not exceed half the size of the smallest structure to be reconstructed.

(6444)

**WARNING!**

Material visualization. The material view displays the combined voxel densities from image set values and material override. Any material override ROIs inside the External ROI, ROIs of type Fixation and Support included in the selected beam set, and ROIs of type Bolus assigned to the selected beam are included in this density computation. The displayed density values are the voxel densities used for dose computation.

When Stopping Power Ratio (SPR) is used as input for proton and light ion dose computation, the material view displays the combined voxel SPR values used in dose computation instead.

The user is advised to carefully review the material values (density or SPR) to ensure that the input to the dose computation is correct.

Note that for BNCT and Brachy TG43, material visualization is not available. For the BNCT technique, the dose computation is performed by an external dose engine and the material handling is different, while for Brachy TG43 dose computation the entire patient is considered as water.

2638

**WARNING!**

Pitch and roll of couch affect patient geometry. When planning or performing imaging with a pitch or roll of the couch, be aware that there is no validation in RayStation that the patient rotation in the image matches the patient rotation in the treatment plan.

(68044)

**WARNING!**

Beams with gimbal angle. For a LINAC that is set up to support gimbal planning it is possible to set gimbal pan and/or gimbal tilt angle for a treatment beam. DRRs, physical depth and water equivalent depth are computed in the beam direction/to the gimbal adjusted virtual isocenter (i.e., including gimbal angles). SSD is reported to the beam/machine isocenter (no gimbal angles applied).

A DRR generated for a beam with non-zero gimbal angles is not suitable for patient setup, as it is not directed at machine isocenter but the gimbal adjusted virtual isocenter.

(937534)

3.1.10 Warnings concerning proton and light ion planning

General proton planning warnings



WARNING!

The user must verify that ion block/MLC/compensator DICOM data is correctly transformed from isocenter to physical plane. The user must verify that their receiving systems use the same transform to achieve the physical block/MLC/compensator as RayStation, based on the tags for VSAD, isocenter to tray distances and properties on the isocenter exported in DICOM. This must be verified for a number of collimator angles, if the machine supports a rotated collimator (snout). (508837)



WARNING!

Constant factor models ignore variations in RBE. Constant factor RBE models will only scale the physical dose with a constant factor to obtain the corresponding RBE dose. Any variations in the RBE due to physical characteristics of the beam, such as Linear Energy Transfer (LET), or due to patient anatomy, such as cell types, are disregarded. Specifically, the increase in RBE at the end of range is neglected. The user should be aware of these limitations. (612056)

PBS proton and light ion planning warnings



WARNING!

Air gap value for fixed snouts. The air gap value for fixed snouts should only be set or changed if the user plans for non-isocentric treatments. For fixed snouts, the patient position will be adjusted along the beam center line to achieve the desired air gap. (125586)

**WARNING!**

Beams eye view (BEV) for ion delivery systems. The projections of objects from the physical plane to the isocenter plane in the BEV are carried out as a scaling with a single SAD. This means that for ion machines with SAD different in X and Y, the isocenter projections of snout mounted objects and ROIs away from the isocenter plane may not appear to be correct. The visualization error increases with object distance from the isocenter plane. However, the projections of the block aperture contours in the BEV have been compensated for this effect and are visualized correctly. The effect for ROI contours close to the isocenter is negligible, but for non-isocentric treatments the effect could be noted. This is a visualization limitation only and does not affect the dose computation. [136852]

**WARNING!**

Evaluate the LET_d distribution after optimization. If LET functions have been used during the optimization, the plan shall be carefully reviewed both with respect to dose and LET_d. Combined dose and LET_d functions may result in conflicting optimization goals, and LET_d is only a predictor of biological effect if analyzed together with the dose.

[?22444]

Specific PBS proton planning warnings

**WARNING!**

Avoidance structures for Sumitomo Line Scanning. When using the Avoidance structures functionality for Sumitomo Line Scanning, the user needs to be aware that line segments can be placed inside the selected avoidance ROIs. This occurs when different parts of the target volume are present on opposite sides of the selected ROIs in the scan direction. Choosing a different scan direction can help to mitigate the problem.

[144761]



WARNING!

Evaluation of PBS arc plans. If a PBS arc plan is converted to an equivalent PBS plan for treatment delivery using the Convert to PBS function, then the quality and robustness must be evaluated on the converted PBS plan.

{711947}



WARNING!

Avoid PBS arc sectors that pass over a couch border. When planning using the PBS arc treatment technique, users must be aware that arcs that cross a couch border can be highly sensitive to setup errors. Users are advised to avoid such setups by splitting arcs into sectors contained in different beams.

{723432}



WARNING!

Robustness of PBS arc plans. Since spots are delivered from multiple directions in PBS arc plans, robustness becomes more challenging than in IMPT. A setup shift, range error, or change in the patient anatomy will affect spots differently for the different directions and the combined dose distribution from the spots can deteriorate severely unless correct measures are taken. The user is advised to always employ robust optimization to mitigate these problems, and to perform robustness evaluation of the resulting treatment plan.

It should be noted that anatomical changes over the course of treatment cannot always be accounted for in robust optimization. Due to the higher sensitivity of PBS arc plans, the user is therefore advised to always assess the interfractional robustness of PBS arc plans when the anatomy changes between fractions.

{723485}

US/SS/DS/Wobbling proton planning warnings



WARNING!

Always verify that the compensators created in the Proton beam design module can be manufactured. It is not possible to define all compensator manufacturing constraints in RayStation. It is the responsibility of the user to ensure that the compensator can be manufactured with respect to any limits on the drilling depths, since this is not explicitly handled in RayStation. However, any maximum drilling depth can be implicitly accounted for by the minimum and maximum compensator thickness limits that are defined when adding or editing a beam. {508893}

3.1.11 Warnings concerning TomoHelical and TomoDirect planning



WARNING!

Collision avoidance for TomoHelical and TomoDirect. After isocenter adjustments, always make sure that the patient will fit comfortably on the couch in the gantry bore. The 2D and 3D views include machine specific FOV and Bore visualization that can be used to verify that no collisions will occur. Do not use the Room view to verify collision avoidance. {254787}



WARNING!

TomoDirect treatment through the couch. The TomoTherapy couch consist of a fixed lower pallet and a movable upper pallet. The upper pallet position during delivery can be different from the planning position due to lateral patient setup adjustments. This can influence dose for beams entering through or close to the edge of the upper pallet. Daily gantry roll corrections can also change the path of the beam through the couch. Avoid creating TomoDirect plans with a large fraction of the dose from beams entering through or close to the edge of the upper pallet.

{5062}



WARNING!

Single Patient DB per iDMS. An iDMS shall only receive data from one Patient DB in order to avoid consistency errors. A patient lock in Patient DB ensures that the same patient is not exported to iDMS simultaneously from two RayStation instances.

[261846]



WARNING!

Motion synchronization for TomoHelical plans. When motion synchronization is used for a TomoHelical plan, three imaging angles (0, 90, 270 degrees) are created as a starting point. The user needs to manually edit the angles, evaluate them and make sure that they are appropriate for imaging of the selected targets to track.

At approval or export, the angles are validated to ensure that they do not violate some constraints. For example, all angles need to be separated by at least 30 degrees. However, note that there is no validation that the angles are well-suited to be used for target tracking.

[143545]



WARNING!

Do not use 'Fiducial' in ROI/POI names when using TomoHelical with Synchrony.

For TomoHelical plans using real-time tracking and motion management support, 'Fiducial' should not be used in the ROI/POI name. The Treatment delivery system identifies which fiducials to track by this naming convention. Using the name 'Fiducial' in ROI/POI names might cause problems on the delivery side with incorrect ROI/POIs to be set as tracked as well as duplicate ROI/POI names. Incorrect fiducial usage will result in failure to deliver the plan on the machine.

[282912]

3.1.12 Warnings concerning CyberKnife treatment planning



WARNING!

A created 1-view margin ROI has no dependency on the selected tracking technique or source ROI. After a 1-view margin ROI is created, it has no dependency on the motion synchronization technique of the beam set, nor on the source ROI. If the motion synchronization is changed, or the source ROI is updated, regenerate the margin ROI.

[341543]

3.1.13 Warnings concerning BNCT treatment planning



WARNING!

Collision avoidance BNCT. The patient/machine setup must be manually verified for all beams to avoid collisions causing patient injury or equipment damage. No checks are performed in RayStation to ensure that the collimator does not overlap with the patient. [611925]



WARNING!

BNCT material handling. For BNCT dose computation, each dose grid voxel is assigned exactly one ROI from which the corresponding material and cell type information is obtained and used by the external dose engine, assuming the entire voxel to have these properties. The ROI with the largest relative volume is assigned to the entire voxel. ROIs, or parts of ROIs, that are small compared to the size of the dose grid voxels may therefore not be included in the dose calculation. Care should be taken to choose the dose grid voxel size accordingly.

Note that the voxels on the patient surface will be assigned the ROI with largest coverage in that voxel, even if the ROI only covers a small part of the voxel. The result is that the interpretation of the patient surface in the dose computation can become larger than in the image data. The user must be aware of this limitation for BNCT dose computation.

[724224]

**WARNING!**

Use of cell type doses in BNCT plan reports. Plan reports for BNCT plans will present data (DVHs; clinical goals; prescription dose references and dose statistics) evaluated on the corresponding cell type doses for any ROI with cell type and material assigned, except for the External.

Only the default (non cell type) dose will be shown in the 2D views.

1201289

3.1.14 Warnings concerning brachytherapy treatment planning

**WARNING!**

Validation of application setup properties prior to clinical use. It is the user's responsibility to validate that the parameters defined for an application setup correctly represent the corresponding applicator before clinical use. In particular, the correct position of the dwell points must be verified.

(283879)

**WARNING!**

Dwell time limits. The dwell time limits in RayPhysics are based on the reference air kerma rate at the specified reference date and time for the current source; no decay correction is applied at the time of planning. Ensure that the specified limits account for the full expected range of decay correction factors over the lifetime of the source - in particular, to avoid violating any afterloader constraints on the maximum permitted dwell time.

(283881)

**WARNING!**

Brachytherapy dwell point positioning. The correctness of the in-patient dose distribution strongly depends on the accuracy in positioning of the channels and dwell points. It is the responsibility of the user to verify that the channels are correctly positioned for each patient and that the representation of dwell points inside the channels is correct.

(283361)

**WARNING!**

Reported dose for brachytherapy. All dose values in RayStation are reported as absorbed physical dose for brachytherapy. It is recommended to perform clinical evaluation of brachytherapy treatment plans using the biologically weighted EQD2 dose in addition to the absorbed dose. There is currently no direct display of EQD2 doses in the graphical user interface and it is the responsibility of the user to convert reported dose values to EQD2 doses.

(284048)

**WARNING!****Summation of brachytherapy and external beam radiotherapy doses.**

Brachytherapy treatment plans normally hold significantly higher fraction doses than external beam radiotherapy plans. When there are large differences in fraction dose prescriptions, doses should not be summed directly without considering radiobiological effects (using concepts such as BED and EQD2).

(283362)

**WARNING!**

Limitations of the EQD2 formalism. The equivalent dose in 2-Gy fractions (EQD2) implemented in RayStation is based on the standard linear-quadratic (LQ) model, which has the following implications that the user should be aware of:

- The model assumes complete repair between fractions and disregards repopulation of tumor cells. Therefore, in cases where complete repair between fractions is not achieved, the biological effects will not be adequately modeled. Furthermore, when repopulation of tumor cells becomes important, for example due to interruptions in the treatment or for rapidly proliferating tumors, the EQD2 dose will not be fully correct.
- The uncertainties in the LQ model become larger for low prescribed doses (below 1 Gy) and high prescribed doses (8 Gy) per fraction. Consequently, the EQD2 doses are less reliable for such dose levels.
- The EQD2 doses are strongly dependent on the α/β -values used in the evaluation. The user is advised to consider a range of α/β -values in the evaluation and investigate worst-case scenarios for EQD2, especially when normal tissue tolerance may be compromised.
- EQD2 doses do not depend linearly on the physical dose, which means that cold and hot spots are enhanced when translating physical dose to EQD2 and gradients in the EQD2 distribution are higher than in the physical dose distribution. It is therefore advised to not evaluate EQD2 in a single point only but use multi-point evaluations to account for differences throughout the volume. Furthermore, when the EQD2 evaluation is based on volumes in the DVH, it is advised to use more than one clinical goal. For example, a clinical goal on EQD2(D90) could be complemented with clinical goals for other accumulated volumes than 90% of the total ROI volume. Volume effects can be analyzed further in the full EQD2 distribution, as obtained from the EQD2 computation in Plan evaluation.

(406776)

**WARNING!**

Interpretation of EQD2 distributions. An EQD2 distribution differs from the corresponding physical dose distribution in several aspects and special care must be taken when interpreting EQD2 dose distributions:

- Evaluation criteria for physical dose cannot be used directly when evaluating EQD2 distributions. The physical dose criteria must always first be converted to the EQD2 domain. This is essential also for treatments prescribed at 2 Gy per fraction to the tumor: even if the prescribed dose in the tumor will be 2 Gy per fraction both in physical dose and in EQD2, cold and hot spots inside the tumor will be enhanced in the EQD2 domain. More importantly, normal tissue tolerances can differ significantly between the physical dose and the EQD2 distribution also for 2 Gy-fractionated treatments.
- For an EQD2 distribution computed in Plan evaluation, adjacent or overlapping ROIs can be assigned with different α/β -values and the EQD2 distribution will be discontinuous across boundaries between ROIs with different α/β -values. For overlapping ROIs, a priority between the ROIs in the EQD2 computation determines which α/β -value to be used in a voxel belonging to more than one ROI. The result is that the α/β -value specified for an ROI may only be used in part of the ROI.
- To ensure that a specific α/β -value is used to evaluate a clinical goal in the EQD2 domain, it is recommended to first extract the clinical goal for the physical dose and then convert it to EQD2 with the α/β -value of choice, rather than extracting the clinical goal directly from the EQD2 distribution. Reporting of EQD2 metrics is common in brachytherapy, and RayStation supports EQD2 clinical goals in the brachytherapy module, which automatically performs the recommended conversion.

(408774)



WARNING!

Brachytherapy applicator models must be validated before clinical use. It is the responsibility of the user to validate all brachytherapy applicator models before they are used in clinical brachytherapy treatment plans.

RayStation is developed to be used by trained Radiation Oncology professionals. Users are strongly advised to adhere to industry standards for quality assurance of brachytherapy applicators and treatment planning. This includes performing dosimetric verification using methods such as gafchromic film measurements, as recommended by the American Association of Physicists in Medicine (AAPM) in *Task Group 56 (TG-56) on the quality assurance of brachytherapy equipment and Medical Physics Practice Guideline 13.a*.

It is also strongly advised to create a structure template and, after completing relevant quality assurance checks, to approve the template to ensure that the applicator structures are not unintentionally changed. During the treatment planning process, users should only use structures from these approved templates to maintain consistency and accuracy in treatment delivery.

[726082]



WARNING!

Review channel lengths. The inner and effective channel lengths are critical values communicated directly to the afterloader for the execution of the treatment plan. It is imperative to recognize that any discrepancy in the channel lengths may not be detected by the machine. Errors in these values can result in significant deviations from the intended treatment.

When channel lengths are edited during treatment planning, it is essential to confirm that all edited lengths accurately reflect the intended treatment setup prior to the final approval and delivery of the treatment plan.

[936234]

3.1.15 Warnings concerning robust optimization



WARNING!

Evaluate the dose after robust optimization. After a robust optimization has been performed, the user is strongly advised to evaluate the dose using Robust evaluation, Plan evaluation or the scripting functionality in RayStation to verify that the plan is robust with regards to all relevant uncertainties during delivery.

[10775]



WARNING!

Be aware how the different types of robustness affect the plan optimization.

Different robustness types (systematic, interfraction, intrafraction) depend on different assumptions of underlying uncertainty and will result in different types of plans. The user needs to be aware of the effect of the robustness setting, and evaluate the plan with respect to the type of uncertainty it is set to be robust against.

Note that the integrated robustness evaluation tools in the Robust evaluation module only considers systematic uncertainties with the same uncertainty for all beams and isocenters. For plans optimized robustly with independent beams, independent isocenters, interfractional or intrafractional uncertainties, the user needs to assess the robustness through other means, for example by combinations of evaluation doses from the Plan evaluation module.

[283855]



WARNING!

Conflicting robust optimization functions. Robust optimization functions (e.g., a robust minimum dose function to a target and a maximum dose function to an OAR) may be in conflict also when applied to ROIs that are not overlapping, because of the different scenarios. This may lead to over- or underdosage. [115551]

**WARNING!**

Robust optimization functions may be in conflict with non-robust optimization functions. A robust constraint may, for example, be in conflict with the mimic dose function during the creation of a deliverable plan in the Multi-criteria optimization module. The optimization may prioritize the non-robust functions over the robust functions, leading to reduced robustness. {370077}

**WARNING!**

Fallback plans will not take robustness into consideration during mimic dose optimization. If the original plan was optimized using robust optimization functions and a fallback plan is created, the fallback plan will try to mimic the dose of the original plan without taking robustness into consideration. {115556}

**WARNING!**

Evaluate the LET_d distribution after robust optimization. After performing a robust optimization with LET functions, the user is strongly advised to evaluate the LET_d distribution using Plan evaluation or the scripting functionality in RayStation to verify that the plan is robust with regards to all relevant uncertainties during delivery. {722447}

3.1.16 Warnings concerning dose evaluation

**WARNING!**

Interpolated dose values are shown in the patient views. Interpolated dose values are shown in the patient views by default. Ensure that an appropriate dose grid resolution for the specific treatment planning situation is used. {3236}

**WARNING!**

Display of total dose. It is always the total dose for all planned fractions that is displayed in the patient views, the DVH graph, the dose statistics and in the clinical goals list.

Exceptions are the QA module, where the dose is displayed for one fraction, and the Dose tracking module, where the user can select different scales of displayed dose.

[3233]

**WARNING!**

System checks at approval. Be aware that the following checks before approval are only performed for planning doses:

- Beam entry validation.
- A Bolus ROI geometry exists.
- A Support ROI geometry exists.
- A Fixation ROI geometry exists.
- The Dose grid resolution is smaller than 5 mm in all directions.

For evaluation doses, the user is responsible for performing these checks.

Note that having a planning dose grid which encloses the External ROI, support ROIs, fixation ROIs and bolus ROIs does not guarantee that all relevant regions are included for dose computation on additional datasets. [508962]

**WARNING!**

Approximate dose is only intended for intermediate treatment planning steps.

Approximate dose has lower accuracy compared to the dose displayed as "Clinical" and it must not be used for clinical decisions. A plan with approximate dose cannot be approved or exported.

[9405]



WARNING!

Delivery times in RayCare are not reported back to the dose tracking treatment course in RayStation. This means that repopulation and repair factors for biological clinical goals evaluated in Dose tracking workspace will not account for changes in delivery times.

[142227]

3.1.17 Warnings concerning biological optimization and evaluation



WARNING!

Always evaluate the dose distribution when using biological functions. Biological functions can be used as tools to create and evaluate a plan, but the resulting dose distribution must always be evaluated. [508965]



WARNING!

Biological models. When using biological models, carefully review the selection of model parameters before clinical use. [508966]



WARNING!

Biological model parameters. The biological model parameters are only valid if the correct reference volume is outlined when creating the ROI. [508967]



WARNING!

Factory default biological models. The database of factory default biological model parameters comes from published clinical and pre-clinical studies for photons. Still, this is an evolving field of science and more recent studies may provide evidence for other biological model parameters to be more suitable for clinical use.

The user shall always review the literature and base their usage of biological model parameters on the current state of knowledge in the field and clinic-specific treatment techniques and modalities. [508968]

**WARNING!**

Biological evaluation and optimization for protons. The biological models used for evaluation and optimization in RayStation are based on studies for photons. Photon equivalent dose must be used when performing biological evaluation and optimization for protons, so the machine model must either include an RBE factor in the absolute dosimetry or be used together with an RBE model. [508969]

3.1.18 Warnings concerning automated planning

**WARNING!**

Plan Generation Protocols. Be aware that any user may edit plan generation protocols. These changes affect all other users at the clinic. [508799]

**WARNING!**

Fallback planning. Be aware that any user may edit fallback plan types and protocols. These changes affect all other users at the clinic.

[4022]

**WARNING!**

Fallback planning for protons. A photon fallback plan created from a proton plan, requires that the proton beam model includes an RBE scaling factor in the beam model or that it is used together with an RBE model in order to make the doses from the photon and proton plans equivalent. [252951]

**WARNING!**

Automated breast planning. The patient has to be prepared with a precise setup of radio-opaque markers and wire before CT scanning. It is crucial that the placement of the markers and the shape of the External ROI are correct. These need to be carefully reviewed before continuing the automated plan generation process. Target ROIs and OAR ROIs are generated based on the markers. The resulting ROIs also depend on image quality and patient anatomy. Always verify the outcome of the automatic ROI generation.

(10431, 594)

**WARNING!**

Automated breast planning. The Automatic breast planning module is designed to be used for tangential breast or chestwall treatment plans only. It is not to be used in conjunction with an adjoining supraclavicular field due to the collimator angle optimization that occurs during generation of an automated tangential plan. This may create regions of over- or underdosage at the junction of the breast/chestwall and supraclavicular fields. If a supraclavicular field must be created, it is recommended to create a plan with another treatment technique according to the clinic's practice.

(7534)

**WARNING!**

Treatment settings for Automated breast planning. Note that the advanced settings may be edited after selecting treatment settings Site and Mode. Hence, the advanced settings might not reflect the current status of the Site and Mode buttons.

(10384)

**WARNING!**

Automated planning. Since there is less user involvement in plan creation when using automatic tools, extra care needs to be taken to manually verify the plan quality in the Plan Approval workspace.

(564)

3.1.19 Warnings concerning beam commissioning

General beam commissioning



WARNING!

Beam model quality depends on beam data. The quality of the beam model depends critically on the quality and scope of the beam data, for example, dose curves, output and wedge factors, absolute calibration, phantom size and collimation settings which influence the curve field setup. The entered measurement conditions must match the measurement technique. The sizes of the measured fields should cover the field sizes of the future applications of the beam model.

All input data, such as measured curves and output factors, must be coherent and correspond to the delivery system which is to be commissioned. Otherwise the generated beam model will not be able to calculate a correct dose.

For more information, refer to the *RSL-D-RS-v2025-BCDS, RayStation v2025 Beam Commissioning Data Specification*.

[3188]



WARNING!

Machine constraints. If the machine constraints defined in RayPhysics do not reflect the treatment machine and R&V-system behavior, the plans can either be stopped at delivery or adjusted outside RayStation giving a situation where the delivered dose differs from the approved dose. When creating a machine model from a template, ensure that all machine constraint parameters are adapted to your specific treatment machine.

Even if RayStation adheres to all machine constraints specified in RayPhysics, there is no guarantee that all plans will be possible to deliver. Ensure that plans are not modified outside RayStation in a way that significantly affects dose without proper evaluation.

[3185]



WARNING!

Beam model parameters. The accuracy of the dose computation depends critically on the beam model parameters established during beam commissioning. Before a machine is commissioned, all beam model parameters must be carefully reviewed by a person with proper training.

[9377]



WARNING!

Always review curves after import. Always review curves after import to ensure consistency with the measurement situation. The beam model quality depends critically on correctness of the imported data.

[9373]

C-arm, TomoTherapy and CyberKnife LINAC beam commissioning



WARNING!

Modulated dynamic arc machines require information about collimator motion, gantry motion and dose rates. Deviation between the selected values and LINAC/R&V-system behavior may result in differences between delivered dose and dose approved in RayStation.

[3183]



WARNING!

Siemens virtual wedge. The Siemens virtual wedge parameters mean linear attenuation and calibration shall be adjusted from the default values to the proper values for your LINAC. Failure to do so may lead to error in the computed clinical dose.

[3180]

**WARNING!**

Dose curve wedge orientation. The wedge orientation for wedged curves is determined from the curve at import. All wedge angles must have been measured with the same orientation. If all curves do not have the same wedge orientation, then no curves will be imported. For curves where the orientation cannot be determined, it is assumed to be identical to other curves imported at the same time.

(9371)

**WARNING!**

Collimator calibration. The collimator calibrations (offset, gain and curvature) are used to shift the collimator positions from the plan positions (shown in the Beam's Eye View, in beam lists, in reports, exported in DICOM etc.) to an effective position used in dose computation. For dose curves this only shifts the penumbra, but for a VMAT, SMLC or DMLC field with many segments adding up, this can change the overall dose level significantly. Ensure that the collimator shift in the beam model is really intended. Be extra careful with gain and curvature shifts which increase with increasing distances from the origin. Results from the auto-modeling collimator calibration step must be reviewed before clinical use.

(9368)

**WARNING!**

Beam profile correction and off-axis softening at large field radii. The photon beam model parameters *Beam profile correction* and *Off-axis softening* cannot be evaluated at large radii in the Beam commissioning module without having imported diagonal profiles which extend to the corners of the field. Special care must be taken when using auto-modeling for the *Beam profile correction* and *Off-axis softening* parameters if there are only x- and y-profile curves imported into the Beam commissioning module. Be aware that manual adjustments of these parameters at large radii will be necessary after using auto-modeling without diagonal curves. The Physics mode application can be used to check the calculated dose of the entire field, including corners, before commissioning a machine.

(3438)

**WARNING!**

Non-standard fluence mode. When modelling a photon beam quality with non-standard fluence mode (FFF/SRS), it is essential to select the correct fluence mode when adding the beam quality. If the fluence mode is not set correctly, plans using the beam quality may be misinterpreted by the LINAC, leading to incorrect delivered dose.

If standard fluence mode is used for the beam quality, RT Plans will set Fluence mode to "STANDARD" and the Fluence mode ID is not exported.

If non-standard fluence mode is selected, RT Plans will set Fluence mode to "NON_STANDARD" and the Fluence mode ID to the selected fluence mode (FFF/SRS).
(9365)

**WARNING!**

Dose computation photon beam energy and nominal photon beam energy. The RayStation photon dose computation internally uses a photon energy definition according to BJR #11 (British Journal of Radiology supplement number 11). It is possible to specify a nominal photon beam energy which is different from the dose computation energy, for example to use a photon energy definition according to BJR #17.

The nominal energy will be displayed in the RayStation user interface, used in reports and as DICOM Nominal Beam Energy in both DICOM import and export.

The dose computation energy will be used for photon dose computation, including to get the correct golden segmented treatment table (GSTT) parameters for dose computation with Varian Enhanced Dynamic wedge. It is therefore crucial to set a correct dose computation energy regardless of the selected energy definition.
(4889)

**WARNING!**

High-dose Technique Type settings. Thresholds should only be set for treatment techniques intended for use with high dose technique types. The thresholds allow a safety control of the treatment machine to be overridden. This could potentially lead to a harmful treatment if the values are set incorrectly. An appropriate Maximum beam MU limit should also be set.
(825142)

**WARNING!**

TomoTherapy leaf latency offsets affect both dose output and shape. Leaf latency offsets are imported from iDMS, and can also be edited in RayPhysics. Changes to leaf latency offsets may have different effect for different jaw field sizes, projection times and leaf opening times. Ensure that dose accuracy is validated for all jaw openings and over the full range of clinically relevant projection times and leaf opening times before using the model clinically.

[1404]

**WARNING!**

TomoTherapy dose computation accuracy for short leaf open times and short leaf close times. For TomoHelical and TomoDirect plans with a large number of short leaf open times or a large number of short leaf close times, the delivered dose may differ significantly from the computed dose. The reason is that for fast leaf movements, the treatment machine will not open/close the leaves in accordance with the model used in the dose computation.

To avoid short leaf open times and short leaf close times when creating plans in RayStation, use the beam model parameters *Minimum leaf open time* and *Minimum leaf close time*. The issue will occur with certain machine-specific leaf open/close time characteristics, but around 50 ms can normally be an appropriate value for both *Minimum leaf open time* and *Minimum leaf close time*.

To find the appropriate values for *Minimum leaf open time* and *Minimum leaf close time* for each TomoTherapy treatment unit, leaf latency data can be measured as described in Westerly DC, Soisson E, Chen Q, Woch K, Schubert L, Olivera G and Mackie TR, *Treatment planning to improve delivery accuracy and patient throughput in helical tomotherapy*, *Int J Radiat Oncol Biol Phys.* 2009;74(4):1290–1297. Another option is to use scripting to create a set of test plans with a constant leaf open time for all open leaves and then examine the relation between measured dose and opening time.

[7551]

3.1.20 Warnings concerning scripting



WARNING!

Validate all scripts for their intended use. Carefully validate all scripts before they are used clinically. Be aware that not all actions are scriptable/recordable. Scripting is not intended for unauthorized use, beyond the indications for use described in the RayStation labeling. A recorded script may not be equivalent to the GUI steps performed in RayStation when recording.

[508971]



WARNING!

Use exception handling with care. When executing a script, exceptions not caught in the script will be handled by the script framework automatically, causing the script execution to stop and an error message to be displayed.

If exceptions are manually caught in the script (by adding exception handling to the script), it may override the script framework exception handling and as a consequence, the error message will not be displayed.

If exception handling is added to the script, ensure that all important error messages are displayed. [508972]



WARNING!

Review GUI warnings and notifications when using scripting. The user must be aware that when running a scripted workflow without monitoring the graphical user interface (GUI), the user may miss important notifications and warnings. It is the responsibility of the user to make sure that all information retrieved from scripting is valid when used for clinical decisions by reviewing the GUI. This is especially important when retrieving information from evaluation doses or robust evaluation scenario groups, since they are not part of the plan approval process.

[723283]

**WARNING!**

Coordinate systems in Scripting. In scripting, coordinates are always interpreted according to the DICOM coordinate system specification. For machine coordinate systems, the IEC standard and the DICOM standard are equivalent but for patient coordinates, they differ, see *section 5.1 The patient coordinate system on page 132* and *section 5.2 Patient coordinate system in the DICOM export on page 133*. Machine scales are not taken into account. {508973}

**WARNING!**

Dose units in scripting. In scripting, dose is always measured in cGy. Clinic settings for Gy/cGy are not taken into account.

{3200}

**WARNING!**

LET units in scripting. LET is always measured in MeV/cm in scripting, whereas keV/ μm is used in the RayStation user interface.

{407284}

**WARNING!**

Dosimetry unit in scripting. In scripting, the primary dosimetry unit is always MU. Configuration of other primary dosimetry units is not taken into account. All parameters related to beam meterset are named MU and contains values in MU. However, there exist script methods `GetBeamNP()` and `SetBeamNP()` on ion beams with primary dosimeter unit NP. {126108}

**WARNING!****Care must be taken when setting current object for background scripts.**

A background script is a script marked to run in the computation service. The computation service can supply the background scripts with patient, case, plan, beamset and examination. The patient object can not be changed from the background script. Case, plan, beamset and examination can be changed even if explicitly stated as input parameter.

(141838)

**WARNING!****RayCare operations performed by RayStation scripting cannot be rolled back.**

When RayCare operations are performed in RayStation scripting using the RayCare scripting package, the changes are applied to the RayCare database as soon as the operations have finished. Therefore, these operations cannot be undone or redone using undo/redo in RayStation after the script has finished. The operations are also not rolled back if the script execution is canceled by the user or stopped due to an error in the script. In these situations, the user must either undo the completed RayCare operations manually or write the script in such a way that operations that have already been performed are skipped when the script is executed again.

(282739)

**WARNING!**

Value overflow. Different Python interpreters handle value overflow and infinity differently. Make sure to always handle these cases manually.

(344492)

**WARNING!**

Save shall be avoided in background scripts. A background script is executed by the computation service. The patient state is automatically saved after the script has been executed.

Crashes during the script execution will automatically re-run the script. If the script includes saves, the script has to make sure that repeated retries will not create unwanted states. Domain model rules still apply.

If possible, avoid explicit save of the patient in a background script.

[934662]

**WARNING!**

A background script should avoid generating output that requires user interaction.

A background script has no means of returning the output of the script to the user. The exception are scripts triggered from RayCare where the output information is sent to RayCare for visualization.

A background script should avoid producing output that the user should react upon.

[934663]

3.1.21 Warnings concerning QA

**WARNING!**

Use the exported treatment plan for plan verification. Using the treatment plan for QA measurements provides an opportunity to detect errors in data transfer or dose calculation. It is recommended to only use the QA plan for computing QA dose and to perform QA measurements using the treatment plan. If it, for some reason, is not possible to use the treatment plan for performing QA measurements, make sure that the QA plan setup is as close as possible to the treatment plan setup and that the effects of the differences are understood. [9438]

**WARNING!**

Avoid changing beam angles in the QA plan for ion treatment machines with different beam models for different beam angles. When creating a treatment plan using an ion treatment machine with different beam models for different beam angles, the beam model for a specific beam will be chosen from the corresponding beam angle. If the beam angles are changed in the QA plan compared to the treatment plan (e.g., by collapsing all the beam angles to a chosen beam angle), the dose computation in the QA plan will be based on a different beam model combination than in the treatment plan. The user should therefore avoid changing the beam angles in the QA plan, or if such a change is needed, carefully assess the validity of the QA plan. [149548]

**WARNING!**

Collapse of gantry angles for arc beam QA. Collapse of gantry angles to a single angle for arc beams (VMAT and Conformal Arc) in the QA preparation module is intended for QA with a detector mounted perpendicular to the treatment beam and rotating with the gantry. The dose computed in the QA preparation module can be used, but the QA delivery shall be performed with a rotating gantry to detect any delivery problems related to gantry rotation. For details about dose computation for arc beams and collapsed arc beams, refer to the *RSL-D-RS-v2025-REF, RayStation v2025 Reference Manual*.

[2380]

3.1.22 Warnings concerning EPID QA functionality

**WARNING!**

The EPID QA functionality must only be used together with a validated virtual phantom. The predicted relative EPID QA response strongly depends on the virtual phantom used for EPID QA. To correctly reproduce the relative response in the EPID detector, a thin slab with material override is used to model the metal plate in the EPID detector. The relative response is sensitive to the thickness and material properties of the slab. Therefore, the EPID QA functionality must only be used together with validated virtual phantoms.

[271755]

**WARNING!**

EPID QA doses in the QA preparation module represent relative doses. The resulting dose from the EPID QA calculation, displayed in the QA preparation module, is a corrected, relative dose, even though the color scale displays absolute dose values. The resulting dose has relevance only when exported as a relative dose plane in the same plane as the detector and compared to the measured EPID response.

(271854)

**WARNING!**

The exported RTImage contains the relative response only. The exported EPID dose will be exported as an RTImage for comparison with the response in the EPID detector. The images must be normalized before comparison since the output from RayStation is not calibrated to provide correct absolute dose values. It is therefore not possible to detect any errors in MU scaling through this method. Only errors in the relative fluence will be detected. Also note that the comparison between measured and predicted response is sensitive to the normalization method used.

(271756)

3.1.23 Warnings concerning RayStation Storage Tool

**WARNING!**

Index service. In RayStation 5 and higher, the index service helps the user to keep track of patients in different databases with different database versions. In earlier RayStation versions this is not possible and there is no warning that a patient might have been migrated to a later database version.

(2519)

**WARNING!**

Verify database consistency before upgrade. Before creating a new system based on an existing system in the RayStation Storage Tool, the user must verify the data consistency in the existing system. This can be done by using the *Validate* command in the Storage Tool for systems based on RayStation 7 or later; for systems based on earlier versions, use the ConsistencyAnalyzer tool.

(10241)



WARNING!

RayStation Storage Tool. When RayStation Storage Tool opens a previous version of ResourceDB, the ResourceDB will be upgraded and cannot be used with earlier versions. [261396]



WARNING!

Transfer mode for secondary databases. If a patient database is used as a secondary database in more than one system, the transfer mode is the same.

[466425]

3.1.24 Warnings concerning machine learning



WARNING!

All machine learning models must be commissioned by the user before they are applied clinically.

[69047]



WARNING!

Machine learning planning has not been validated for adaptive replanning

[410648]



WARNING!

Review model data sheet prior to clinical use of machine learning model. Prior to clinical use of a machine learning model, the user must review the associated model data sheet to understand model limitations and intended purpose.

[1202413]

**WARNING!**

The predicted machine learning dose shall not be used for making clinical decisions. The predicted machine learning dose is only visualized to provide the user with transparency into the output of the machine learning model.

(936842)

3.1.25 Warnings concerning medical oncology

**WARNING!**

Approve cycle before delivery. RayStation checks administration dose limits and lifetime dose limits, and that vitals and active substances are in the database and are not deprecated. To ensure that a planned cycle passes all safety constraints checked by RayStation, the cycle must be approved by the user before delivery.

(226201)

**WARNING!**

Regimen reports. RayStation does not keep track of reports created for medical oncology plans. It is the responsibility of the user to keep track of regimen reports created for medical oncology plans.

(141788)

**WARNING!**

Computed dose unit. The only supported unit for computed dose is mg. The dose is computed with an accuracy of two decimal points.

(144557)

**WARNING!**

Maximum lifetime dose of an active substance. RayStation displays warnings and prompts the user at approval if the accumulated lifetime dose of a medication activity exceeds the maximum lifetime dose of the medication activity's active substance. The maximum lifetime dose is set when adding an active substance in RayPharmacy. The accumulated lifetime dose for a medication activity is calculated as the sum of the calculated dose of the medication activity, the doses for medication statements with the same active substance as the medication activity, and the calculated doses of medication activities with the same active substance and in the same regimen that occur prior to the medication activity. It is the responsibility of the user to make sure that the entered medication statements are correct, that all relevant medications delivered to the patient prior to the current regimen are included, and that the maximum lifetime dose of an active substance is correctly entered. Note that medication activities in other plans or regimens are not taken into account.

[144428]

**WARNING!**

Maximum administration dose of an active substance. RayStation displays warnings and prompts the user at approval if the maximum administration dose of an active substance has been exceeded. The maximum administration dose is set when adding an active substance in RayPharmacy. It is the responsibility of the user to make sure that the entered maximum administration dose is correct. Also note that the maximum administration dose only concerns a single medication activity. Multiple medication activities within the same treatment day are not summed to determine if the accumulated dose exceeds the maximum administration dose.

[144555]

3.1.26 Warnings concerning clearance check with MapRT

**WARNING!**

The clearance check shall not be used as a final protection against collisions in the treatment room. The accuracy of the clearance check is approximate. Its purpose is to reduce the probability of a collision during standard patient collision avoidance verification before treatment. The clearance check shall not replace standard collision avoidance procedures prior to patient treatment.

[1095407]

**WARNING!****External machine accessories may not be considered in the clearance check.**

External machine accessories such as blocks, cones, wedges and electron applicators are not considered in the clearance check unless they are explicitly present in the MapRT room model. Clearance maps shown in RayStation are not reliable for such beams and may, in reality, include larger or additional regions with collisions.

[1096363]

**WARNING!**

The clearance check only uses the surface scan as input. The presence or absence of a bolus for a specific beam is not considered in the clearance check.

[1095417]

**WARNING!**

Verification of image set and treatment position. The user must verify that the imported surface scan geometry matches the corresponding image set by inspecting the 2D and 3D patient views. The user must also verify that the surface scan matches the intended patient treatment position.

[1095410]

**WARNING!**

Verification of sufficient accuracy. Some fixation and support devices as well as parts of the patient may be absent from the CT image and the surface scan. In some situations, the patient surface may also exhibit artefacts or gaps. Such a surface scan may not have sufficient accuracy for a reliable clearance check. The user must therefore inspect the imported surface scan and verify that it represents the patient and other relevant structures with sufficient accuracy.

[1153638]

3.1.27 Warnings concerning collision check



WARNING!

The RayStation collision check shall not be used as final protection against collisions in the treatment room. The accuracy of the collision check is approximate. The purpose of the collision check is to provide early indication of a potential collision. The user must supervise the motion of the table top or delivery system in the treatment room.

[408937]



WARNING!

Possible to approve/export plan with collision based on outdated imaging device transformation. The RayStation collision check result is not invalidated if the imaging device transformation (IDT) vector for the treatment room is changed in Clinic Settings. It is the user's responsibility to ensure that the collision check is re-run for unapproved beam sets if the IDT is updated.

[409517]



WARNING!

Create and register avatar. The *CreateAndRegisterAvatar* method is a scriptable method that creates a patient-like avatar that may be used for collision detection.

The avatar is created from a given base model for male, female, or child. The base model is rescaled based on user input of height and weight. The algorithm for rescaling the meshes limits the width of the avatar to approximately 50 cm, which may result in an unrealistic avatar being created, given certain combinations of height and weight.

The user shall be aware that the avatar is only an approximate representation of the patient, and it is up to the user to make sure that the avatar is correctly registered to the given patient ROI before using it for collision detection. The avatar can provide an early indication of a potential collision when used in collision detection, but it shall not be used as a final protection against collisions.

[719240]

**WARNING!**

Register scanned avatar. The Register Scanned Avatar method is a scriptable method that will register an avatar that can be used for collision detection.

The user must make sure that the avatar is a suitable representation of the patient and that it is correctly registered to the given patient ROI before using it for collision detection. The avatar can provide an early indication of a potential collision when used in collision detection but must not be used as a final protection against collisions.

(824789)

3.2 IMPORT OF PATIENT DATA

All patient data is imported using DICOM. The patient data import procedure is described in the User Manual, *RSL-D-RS-v2025-USM*, *RayStation v2025 User Manual*, and the DICOM Conformance Statement, *RSL-D-RS-v2025-DCS*, *RayStation v2025 DICOM Conformance Statement*.

3.3 INPUT DATA

All user input data is validated at the time of input. Incorrect values or text are rejected, correct limits or format is displayed and the user is prompted for new input.

3.4 SCRIPTING

To make sure that everything was executed as expected, carefully study the script execution details after script execution. It is also recommended to study the plan report for all plans that were modified using scripting.

A script shall be validated before clinical use. Carefully review the script content before approval.

An approved script in the database can only invoke other approved scripts.

3.5 DISPLAY FORMAT

In RayStation, date and time are displayed in format "dd MMM YYYY, hh:mm:ss (hr:min:sec)", for example, "14 Jan 1975, 08:20:42 (hr:min:sec)".

4 INSTALLATION INSTRUCTIONS

This chapter describes the processes and tests related to the installation of the RayStation v2025 system.

In this chapter

This chapter contains the following sections:

4.1	Installation manual	p. 130
4.2	System environment acceptance test	p. 130
4.3	Hardware diagnostics checks	p. 130
4.4	Remoting environment setup	p. 130
4.5	Data communication environment	p. 130

4.1 INSTALLATION MANUAL

For installation manual, refer to *RSL-D-RS-v2025-CIRSI, RayStation v2025 Customer Instruction for RayStation Installation*.

4.2 SYSTEM ENVIRONMENT ACCEPTANCE TEST

The system environment acceptance test must be run for each installation or change in hardware or software platform hosting the application (e.g., operating system update) to verify application installation and performance. The test is defined by *RSL-D-RS-v2025-SEAT, RayStation v2025 System Environment Acceptance Test Protocol*.

4.3 HARDWARE DIAGNOSTICS CHECKS

To prevent RayStation or RayPhysics from running in a faulty hardware environment, a self-test is run at the start of each action requiring GPU computation. Depending on which action that is requested (e.g., collapsed cone photon dose) a specific test is run and the result is compared to a predefined list of results from approved environments. A successful test is valid until RayStation or RayPhysics is closed, and the test will not be run again for subsequent actions protected by the same self-test.

If the test fails, the user is notified and no GPU computations will be possible using an action protected by the failing self-test. Other GPU computations where the self-test succeeds can still be run.

The test is run for all GPUs selected to be used for accelerated computations. Nevertheless, it is the responsibility of the user to absolutely ensure that the selected cards together with OS version, driver version and other environment details are listed as valid combinations in the *RSL-D-RS-v2025-SEG, RayStation v2025 System Environment Guidelines*. Additionally, before clinical use, the operation of GPU computations must be verified by a qualified physicist using the *RSL-D-RS-v2025-SEAT, RayStation v2025 System Environment Acceptance Test Protocol*.

4.4 REMOTING ENVIRONMENT SETUP

The remoting environment is set up and validated by RaySearch authorized personnel and should not be changed by the clinic without testing according to the *RSL-D-RS-v2025-SEAT, RayStation v2025 System Environment Acceptance Test Protocol*. The clinic is responsible for ensuring that the remote access policy configuration ensures lossless graphics transfer and similar medical imagery requirements.

4.5 DATA COMMUNICATION ENVIRONMENT

The RayStation v2025 system communicates with other systems using DICOM. For detailed information, see *RSL-D-RS-v2025-DCS, RayStation v2025 DICOM Conformance Statement*. It is the responsibility of the user clinic to establish that the connectivity between RayStation and the systems it imports data from works according to expectations and that exported data is correctly handled by the receiving systems.

5 DISPLAY OF COORDINATES, MOVEMENTS AND SCALES

RayStation v2025 uses the IEC 61217³ standard for display of coordinates, movements and scales during treatment planning, with a few exceptions. The gantry, collimator and couch angles, as well as the field coordinate system may be user configured, per C-arm LINAC, to be non-IEC. Also, some treatment machines are partly described with non-IEC coordinate systems. For more details on the user-defined exceptions, as well as the treatment machine exceptions, see *section 5.3 The treatment machine coordinate system on page 134*.

Note: *Patient positions Head First Supine (HFS), Head First Prone (HFP), Feet First Supine (FFS), Feet First Prone (FFP), Head First Decubitus Left (HFDL), Head First Decubitus Right (HFDR), Feet First Decubitus Left (FFDL), Feet First Decubitus Right (FFDR) and Sitting are supported by RayStation v2025. Not all patient positions are, however, supported for all different treatment techniques.*

In this chapter

This chapter contains the following sections:

5.1	The patient coordinate system	p. 132
5.2	Patient coordinate system in the DICOM export	p. 133
5.3	The treatment machine coordinate system	p. 134
5.4	The jaw and MLC labeling standard	p. 151

³ IEC 61217:2011 Radiotherapy equipment – Coordinates, movements and scales.

5.1 THE PATIENT COORDINATE SYSTEM

The patient coordinate system is oriented with the positive x-axis towards the patient's left arm, the positive y-axis towards the patient head and the positive z-axis in the anterior direction. The coordinate system follows the patient orientation: head first or feet first, supine or prone, decubitus right or decubitus left, and sitting with face towards the front of the chair. For sitting, this means that the patient system is leaned backward with the backrest angle. In the hierarchy of IEC 61217 coordinate systems, the patient coordinate system has the table top coordinate system as its mother system.

The RayStation v2025 dose and the dose difference distributions are all visualized in the patient coordinate system. In general, in RayStation v2025 the patient coordinates are reported as **Right-Left, R-L** (right-left = x -/+), **Inf-Sup, I-S** (inferior-superior = y -/+) and **Post-Ant, P-A** (posterior-anterior = z -/+).

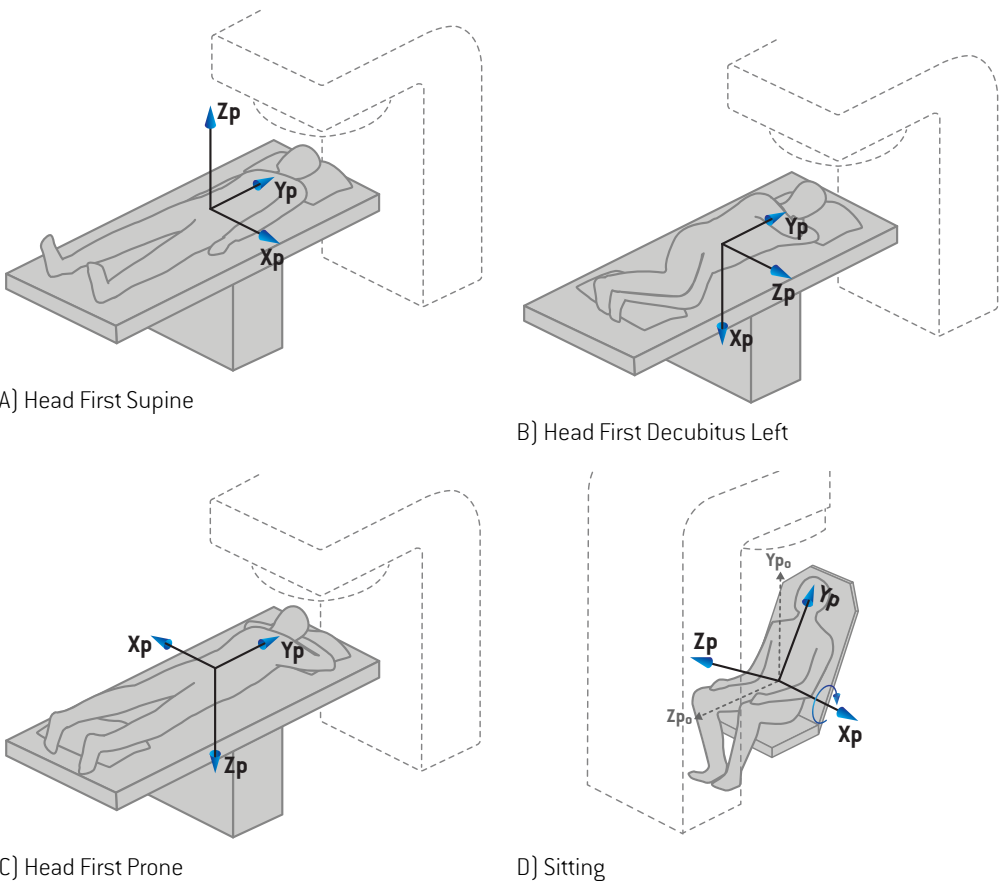

Figure 2. The patient coordinate system. Some examples of supported positions are illustrated: A) Head First Supine (HFS), B) Head First Decubitus Left (HFDL), C) Head First Prone (HFP) and D) Sitting, where the patient is leaned backwards with the backrest pitch angle.

5.2 PATIENT COORDINATE SYSTEM IN THE DICOM EXPORT

Patient coordinates in DICOM exported data sets follow the DICOM standard, with the positive x-axis towards the patient's left arm, the positive z-axis towards the patient head and the positive y-axis in the posterior direction. The coordinate system follows the patient orientation: head first or feet first, supine or prone, decubitus right or decubitus left, and sitting with face towards the front of the chair.

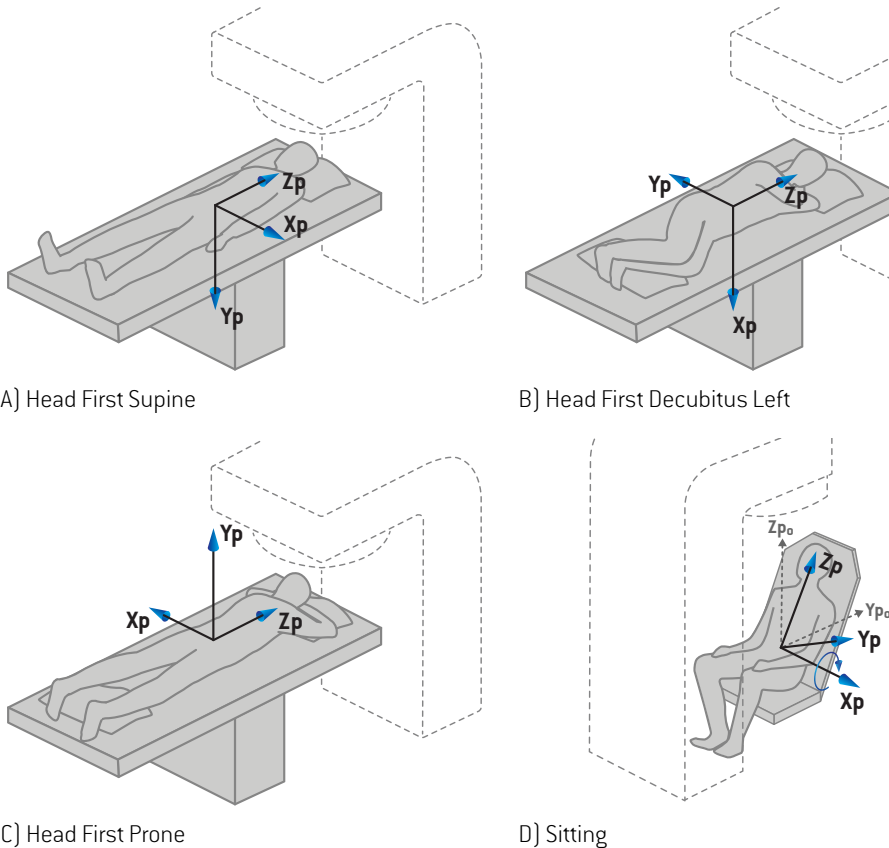

Figure 3. The patient coordinate system in the DICOM export follows the DICOM standard. Some examples of supported positions are illustrated: A) Head First Supine (HFS), B) Head First Decubitus Left (HFDL), C) Head First Prone (HFP) and D) Sitting, where the patient is leaned backwards with the backrest pitch angle.

5.3 THE TREATMENT MACHINE COORDINATE SYSTEM

RayStation v2025 uses the IEC 61217 standard for display of LINAC coordinates, movements and scales during treatment planning, with the exception of gantry, collimator and couch angles as well as the field coordinate systems, which may be configured, per C-arm LINAC, to be non-IEC. There are also two options for jaw labeling. Setup imagers may also be described using non-IEC rotations, see *section 5.3.11 Setup imager coordinate systems on page 149*. The CyberKnife radiation head movements, as well as the gimbal angles used on some machines (e.g. OXRAY), cannot be described using the IEC 61217, see *section 5.3.8 The CyberKnife radiation source coordinate system on page 143* and *section 5.3.9 The gimbal coordinate system on page 146*.

5.3.1 The machine coordinate systems overview

The machine coordinate systems in IEC 61217 are a set of coordinate systems, each defined in relation to its mother coordinate system, starting with a fixed coordinate system which has the origin at the isocenter, the positive x direction to the right for an observer facing the gantry, the positive y-axis from the isocenter towards the gantry along the axis of gantry rotation and the positive z-axis directed upwards from the isocenter.

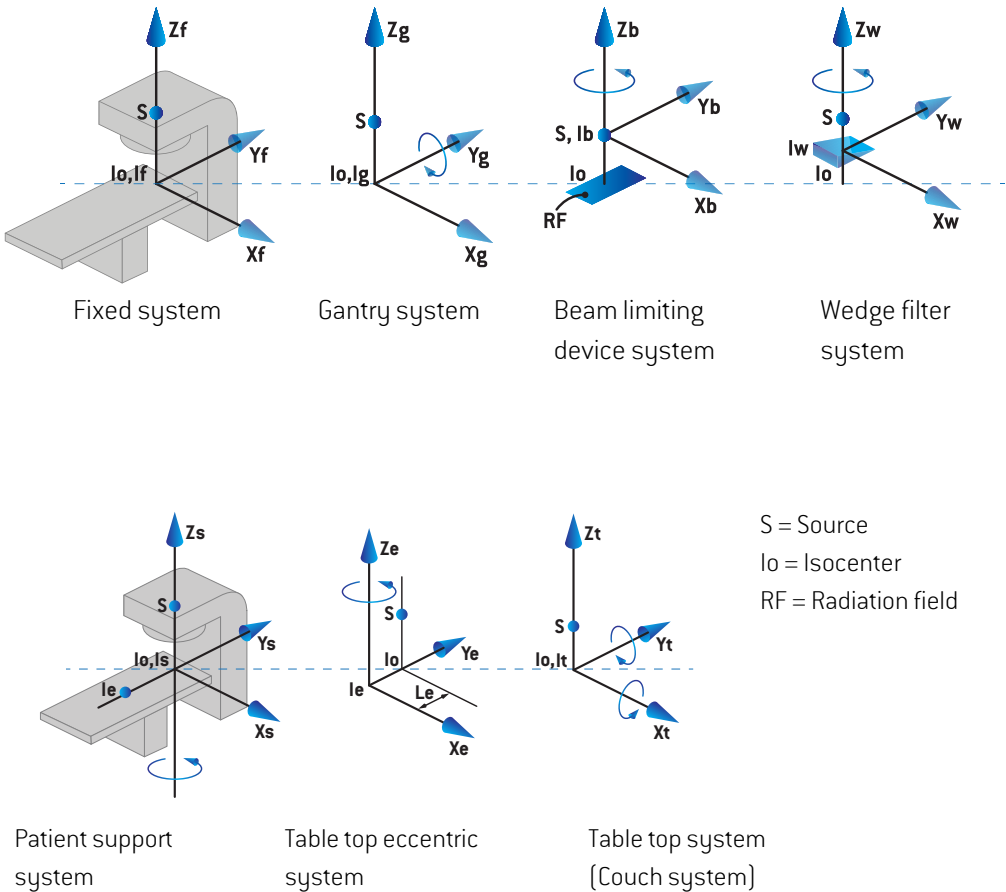

Figure 4. The machine coordinate systems according to the IEC 61217 standard.

If the machine is commissioned to replace the couch rotation by the ring rotation, the rotation around the Z_s axis in the patient support coordinate system is replaced by a rotation in the opposite direction around the Z_g axis in the gantry coordinate system. The relationship between the patient and the gantry systems is thus maintained.

5.3.2 The gantry coordinate system

The gantry coordinate system rotates with the gantry. The gantry coordinate system has the fixed coordinate system as its mother system.

- For **IEC standard**, it is defined to coincide with the fixed coordinate system when the gantry angle is zero. The gantry angle increases gradually for clockwise rotation as viewed by an observer facing the gantry.

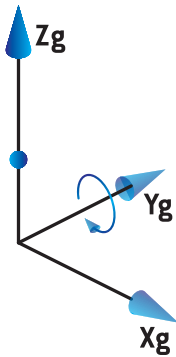

- For **Non-IEC gantry scale (Varian Standard)**, the gantry angle is 180 degrees when the beam enters from above. The gantry angle increases gradually for counter clockwise rotation as viewed by an observer facing the gantry.

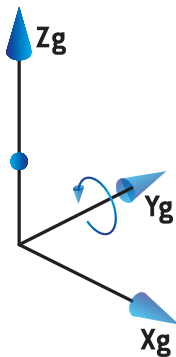

Note: If a LINAC is configured to use gantry angle as IEC 61217, the angle unit is given as [deg].

Note: If a LINAC is configured to use gantry angle as Non-IEC ("Varian Standard"), the angle unit is given as [deg Non-IEC].

5.3.3 The beam limiting device coordinate system

The beam limiting device coordinate system is fixed in the gantry beam limiting device. The beam limiting device coordinate system has the gantry coordinate system as its mother system.

There are three settings in RayPhysics that affect the behavior of angles, positions and names in this coordinate system; the **Gantry and collimator coordinate system definitions**, the **Field coordinate system definitions** and the **Jaw labeling standard**. If all three settings are set to "IEC 61217", the definitions are consistent with those in the IEC 61217 standard.

The Gantry and collimator coordinate system definitions setting

The **Gantry and collimator coordinate system definitions** setting in RayPhysics controls the reporting of the beam limiting device rotation angle:

- For **IEC standard**, the axes coincide with the gantry system when the collimator angle is zero. The collimator angle is defined to be positive for counterclockwise rotation in the Beam's eye view, i.e. when viewed from the source. For this coordinate system, the collimator angle is usually 180 degrees when the tray opening is facing the gantry for Varian machines.
- The **Non-IEC (Varian Standard)** collimator coordinate system is rotated 180 degrees compared to the IEC standard and the collimator angle is defined to be positive for a clockwise rotation in the Beam's eye view, i.e. when viewed from the source. For this coordinate system, the collimator angle is usually zero degrees when the tray opening is facing the gantry for Varian machines.

Note: *If a LINAC is configured to use a collimator angle as IEC 61217, the angle unit is given as [deg].*

Note: *If a LINAC is configured to use a collimator angle as Non-IEC, the angle unit is given as [deg Non-IEC].*

The Field coordinate system definitions setting

The **Field coordinate system definitions** setting in RayPhysics defines how jaw and MLC leaf positions are reported and defined. The following description uses jaw naming convention according to the IEC 61217 standard.

Note: *If a LINAC is configured to use field coordinate system as IEC 61217, the unit for jaw and leaf positions are given as [cm].*

Note: *If a LINAC is configured to use field coordinate system as Non-IEC, the unit for jaw and leaf positions is given as [cm Non-IEC].*

Collimator positions according to IEC 61217

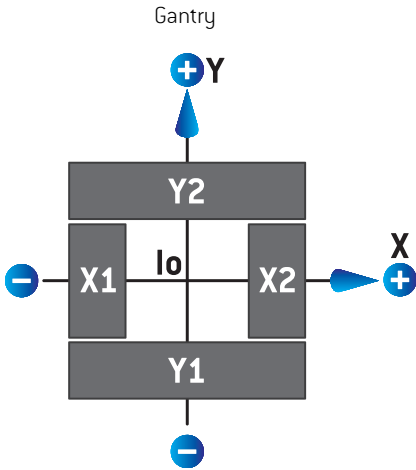

Figure 5. The collimator positions in the Beam's eye view according to the IEC 61217 standard.

The collimator positions according to the IEC 61217 standard, for a beam with (IEC) collimator angle 0 when viewed from the source, are described in the table below.

When the edge of...	is positioned to the ...	of the isocenter axis, its position reading value is ...
X1, X2 (jaw or MLCX leaf)	right	positive
X1, X2 (jaw or MLCX leaf)	left	negative
Y1, Y2 (jaw or MLCY leaf)	gantry side	positive
Y1, Y2 (jaw or MLCY leaf)	non-gantry side	negative

Collimator positions according to Non-IEC (Varian Standard)

For Non-IEC, positive position coordinates are reported in all directions for jaws and leaves that have not crossed the center line. That is, negative coordinates are reported for overtravel.

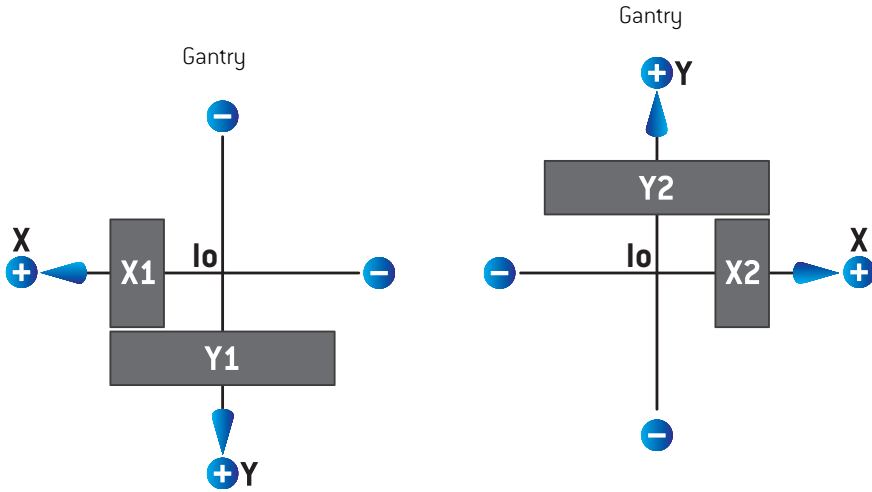

Figure 6. The collimator positions in the Beam's eye view according to the Non-IEC (Varian Standard). Note that the coordinates visualized in the Beam's eye view in RayStation always uses the IEC 61217 coordinate system.

The collimator positions according to Non-IEC (Varian Standard), for a beam with (IEC) collimator angle 0 when viewed from the source, are described in the table below.

When the edge of ...	is positioned to the ...	of the isocenter axis, its position reading value is ...
X1 (jaw or MLCX leaf)	right	negative
X1 (jaw or MLCX leaf)	left	positive
X2 (jaw or MLCX leaf)	right	positive
X2 (jaw or MLCX leaf)	left	negative
Y1 (jaw or MLCY leaf)	gantry side	negative
Y1 (jaw or MLCY leaf)	non-gantry side	positive
Y2 (jaw or MLCY leaf)	gantry side	positive
Y2 (jaw or MLCY leaf)	non-gantry side	negative

The Jaw labeling standard setting

The **Jaw labeling standard** setting in RayPhysics is described in *section 5.4 The jaw and MLC labeling standard on page 151*.

5.3.4 The wedge filter coordinate system

The wedge filter coordinate system rotates with the wedge and the positive y axis points from heel to toe of the wedge. The wedge filter coordinate system has the beam limiting device coordinate system as its mother system. In RayPhysics and the main RayStation v2025 application, the wedge coordinate system is defined to coincide with the selected collimator coordinate system (IEC 61217 or Non-IEC) for a wedge orientation of zero degrees.

- For collimator coordinate system **IEC 61217**, the wedge orientation is zero degrees when the toe points towards the gantry for collimator angle zero.
- For collimator coordinate system **Non-IEC**, the wedge orientation is zero degrees Non-IEC when the toe points away from the gantry for collimator angle zero degrees Non-IEC.

The wedge orientation increases gradually for a counter-clockwise rotation.

Note: *If a LINAC is configured to use a collimator angle as IEC 61217, the wedge orientation angle unit is given as [deg].*

Note: *If a LINAC is configured to use a collimator angle as Non-IEC, the wedge orientation angle unit is given as [deg Non-IEC].*

5.3.5 The patient support coordinate system

The patient support coordinate system rotates with the part of the patient support that rotates around the vertical axis Z_s . The patient support coordinate system has the fixed coordinate system as its mother system.

- For **IEC standard**, the patient support system coincides with the fixed system when the couch/chair angle is zero. The positive rotation direction is defined to be counter-clockwise as seen from above.

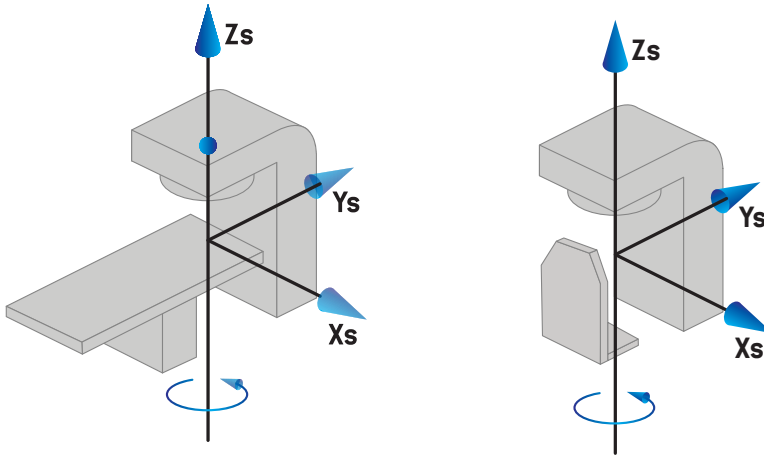

- For **Non-IEC 1 (Varian IEC)** machine scale, the patient support system coincides with the fixed system when the couch/chair angle is zero. The positive rotation direction is defined to be clockwise as seen from above.

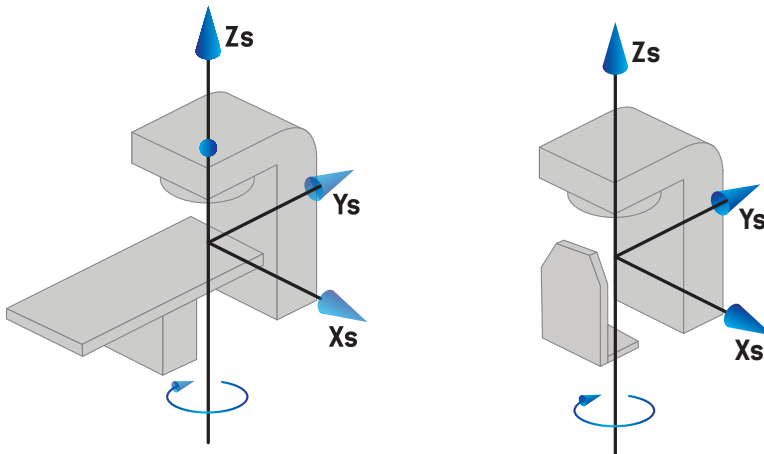

- For **Non-IEC 2 (Varian Standard)** machine scale, the couch angle is 180 degrees when the IEC couch/chair angle is zero degrees. The positive rotation direction is defined to be clockwise as seen from above.

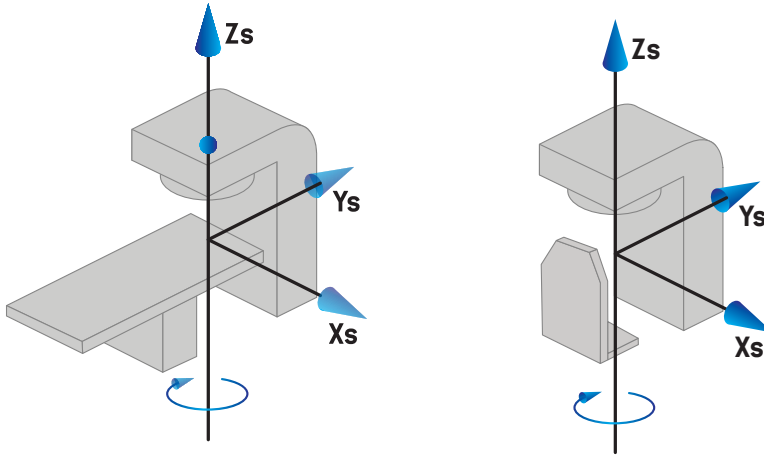

Note: *If a LINAC is configured to use couch angle as IEC 61217, the angle unit is given as [deg].*

Note: *If a LINAC is configured to use couch angle as Non-IEC 1 (“Varian IEC”), the angle unit is given as [deg Non-IEC] in the user interface and as [deg Non-IEC CW] in plan reports.*

Note: *If a LINAC is configured to use couch angle as Non-IEC 2 (“Varian Standard”), the angle unit is given as [deg Non-IEC] in the user interface and as [deg Non-IEC CW] in plan reports.*

5.3.6 The table top eccentric coordinate system

In RayStation, only zero degrees eccentric table top rotation angle and zero translation distance are supported, and thus the table top eccentric coordinate system always coincides with the patient support coordinate system. The table top eccentric coordinate system has the patient support coordinate system as its mother system.

5.3.7 The table top coordinate system

In RayStation, the table top coordinate system has the table top eccentric coordinate system as its mother system. Pitch and roll angles are always expressed using the IEC standard. Subsequent rotations are defined in the order pitch angle followed by roll angle.

- The table top pitch angle is defined as the rotation about axis X_t . An increase in the pitch angle corresponds to the clockwise rotation of the table top as viewed from the table top coordinate system origin along the positive X_t axis.

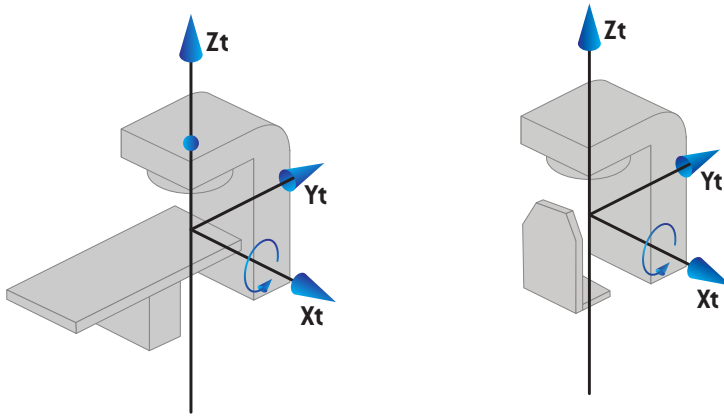

- The table top roll angle is defined as the rotation about axis Y_t . An increase in the roll angle corresponds to the clockwise rotation of the table top as viewed from the table top coordinate system origin along the positive Y_t axis.

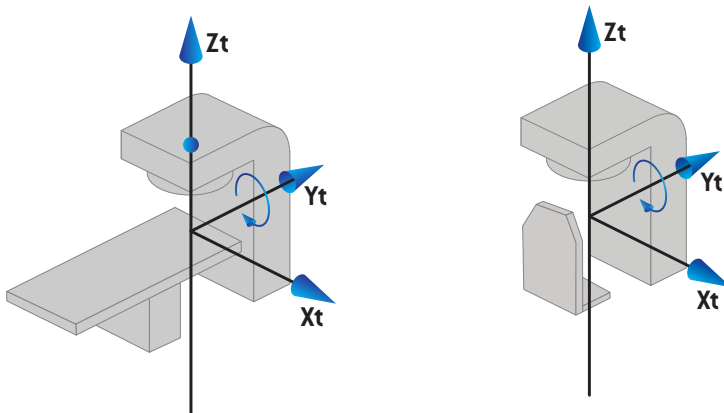

5.3.8 The CyberKnife radiation source coordinate system

The CyberKnife radiation source coordinate system moves with the CyberKnife radiation head and has its origin in the radiation source. The CyberKnife radiation source coordinate system has the fixed coordinate system as its mother system. For CyberKnife treatments, the CyberKnife radiation source coordinate system is the mother system of the beam limiting device coordinate system.

A set of six values defines the CyberKnife radiation source coordinate system in relation to its mother system. The six values are the source position coordinates (C_x, C_y, C_z) and the rotational angles (yaw, roll, pitch).

Source position

The source position (C_x, C_y, C_z) defines the position of the origin I_c of the CyberKnife radiation source coordinate system in coordinates of the fixed coordinate system.

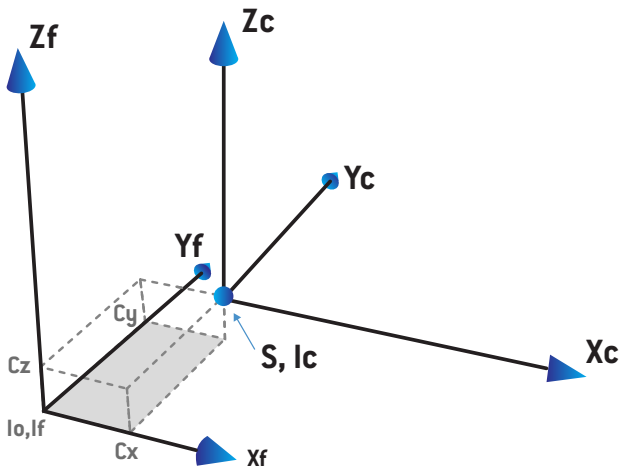
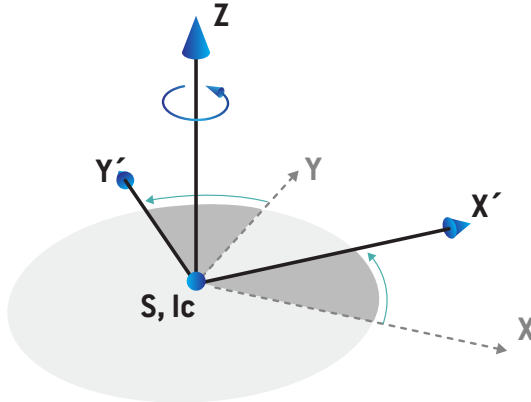

Figure 7. Illustration of the source position where I_o = Isocenter, S = Source, c = CyberKnife radiation source coordinate system and f = Fixed coordinate system.

Rotation

The three rotations yaw, roll and pitch define the orientation of the CyberKnife radiation source coordinate system in relation to its own reference orientation. In the reference orientation the angles yaw, roll and pitch are all 0, and the axes X_c, Y_c and Z_c are parallel to X_f, Y_f and Z_f respectively. The rotations are applied in the order yaw, followed by roll, and followed by pitch. Roll and pitch are rotations about the resulting axes of the former one or two rotations.

- **Yaw** is a rotation of X and Y around Z . The yaw angle increases gradually for counterclockwise rotation, observed from a point on the positive Z axis facing towards the origin. X , Y and Z are the axes of the reference orientation. X' , Y' and Z are the resulting axes from the yaw rotation.



- **Roll** is a rotation of Z and X' around Y' . The roll angle increases gradually for counterclockwise rotation, observed from a point on the positive Y' axis facing towards the origin. X_c , Y' and Z' are the resulting axes from the yaw rotation followed by the roll rotation.

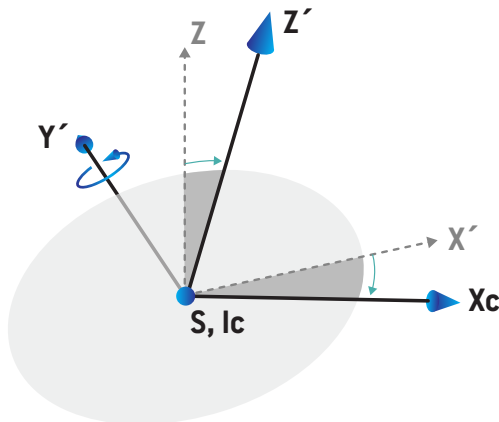

- Pitch** is a rotation of Y' and Z' around X_c . The pitch angle increases gradually for counterclockwise rotation, observed from a point on the positive X_c axis facing towards the origin. X_c , Y_c and Z_c are the final resulting axes after all three rotations; yaw followed by roll followed by pitch.

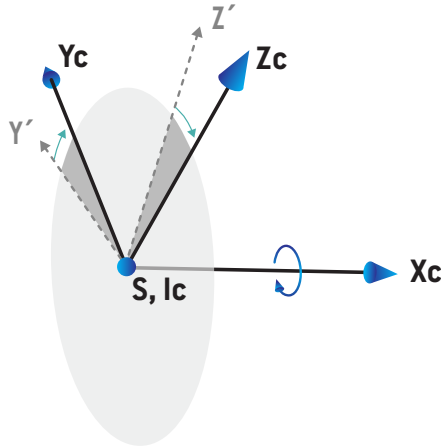

5.3.9 The gimbals coordinate system

The gimbals coordinate system moves with the gimbals and has its origin in the radiation source. The gimbals coordinate system has the gantry coordinate system as its mother system. For treatments with gimbals, the gimbals coordinate system is the mother system of the beam limiting device coordinate system.

A set of four values defines the gimbals coordinate system in relation to its mother system. The four values are the source axis distance, the gimbals rotation center to source distance and the gimbals angles (pan and tilt).

Rotation

The two rotations pan and tilt define the orientation of the gimbals coordinate system in relation to its own reference orientation. In the reference orientation the angles pan and tilt are both 0, and the axes X , Y and Z are parallel to X_g , Y_g and Z_g respectively. The rotations are applied in the order pan followed by tilt, and tilt is a rotation about the resulting axes of the pan rotation.

- Pan** is a rotation of X and Z around Y . The pan angle increases gradually for clockwise rotation, observed from a point on the positive Y axis facing towards the origin. X , Y and Z are the axes of the reference orientation. X_{gb} , Y and Z' are the resulting axes from the pan rotation.

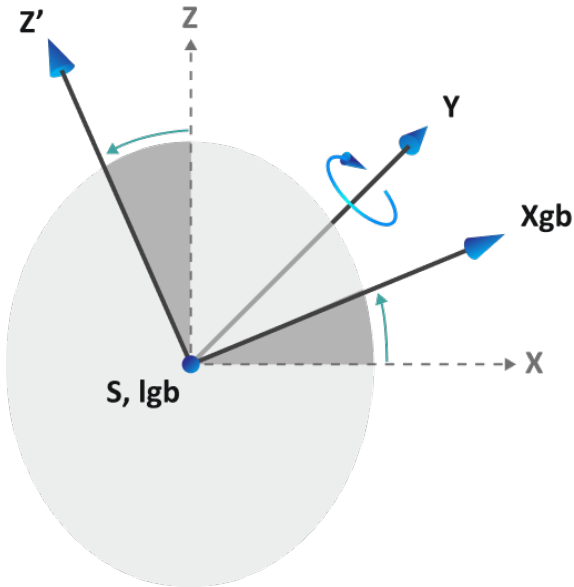

- Tilt** is a rotation of Y and Z' around X_{gb} . The tilt angle increases gradually for clockwise rotation, observed from a point on the positive X_{gb} axis facing towards the origin. X_{gb} , Y_{gb} and Z_{gb} are the resulting axes from the tilt rotation followed by the pan rotation.

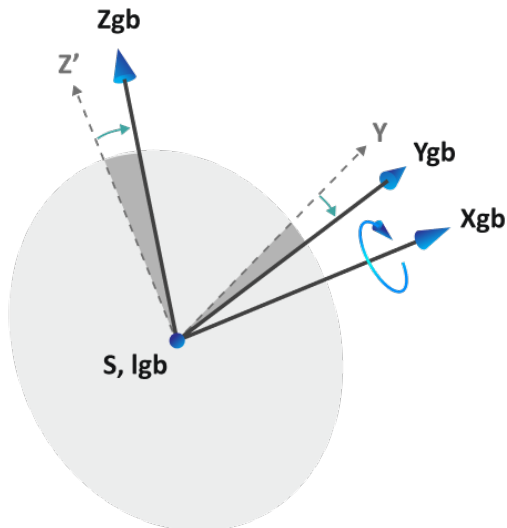

Source position

The gimbal coordinate system has its origin in the radiation source. The position of the origin is defined as two translations of the resulting axes from the rotations described above: X_{gb} , Y_{gb} and Z_{gb} .

- The first translation is along the Z_g to the gimbal rotation center. The translated distance is the source axis distance minus the gimbal rotation center to source distance.
- The second translation is along the Z_{gb} to the radiation source. The translated distance is the gimbal rotation center to source distance.

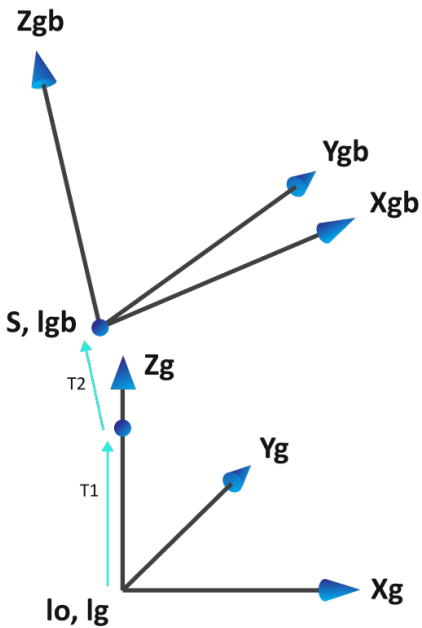

Figure 8. Illustration of the source position where Io = Isocenter, S = Source, gb = Gimbal coordinate system, g = Gantry coordinate system, T1 = first translation and T2 = second translation.

5.3.10 Dose curve coordinate system in RayPhysics

The Beam Commissioning module has a dose curve coordinate system corresponding to the IEC gantry coordinate system, translated so that the origin is on the central axis at the surface of the water phantom. The x-axis is aligned with the cross-line axis. The y-axis is aligned with the inline axis, with the positive direction towards the gantry. The negative z-direction, from source towards isocenter, is aligned with the depth direction. The gantry and collimator angles are always assumed to be zero degrees for the dose curves in the Beam Commissioning module. The model is fully reflection symmetric in the xz- and the yz-plane, whereas measurements can sometimes be mildly asymmetric.

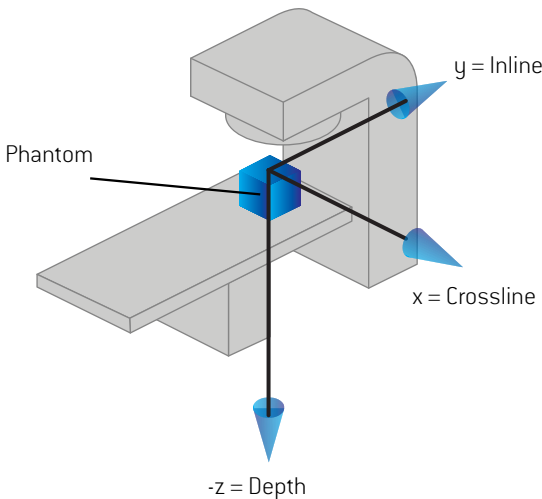

Figure 9. The dose curve coordinate system.

5.3.11 Setup imager coordinate systems

Setup imagers in RayStation are described by the X-ray image receptor coordinate system. It is fixed in relation to the setup imager. The orientation of the X-ray image receptor coordinate system relative to the IEC fixed coordinate system is described using three rotations.

The first rotation is a gantry rotation about the y-axis of the fixed coordinate system, described in [section 5.3.2 The gantry coordinate system on page 136](#).

Note: *The rotation is not necessarily a rotation of the treatment gantry, but a rotation about the y-axis of the fixed coordinate system. Setup imagers only support IEC gantry rotations.*

The second coordinate system, the gantry pitch coordinate system (Figure 10), has the gantry coordinate system as its mother system and is a rotation about the x-axis of the gantry coordinate system. When the gantry pitch angle is zero, the gantry pitch coordinate system coincides with the

gantry coordinate system. The positive rotation direction is clockwise when viewed from the origin along the positive x-axis of the gantry coordinate system. S_r is the imager radiation source.

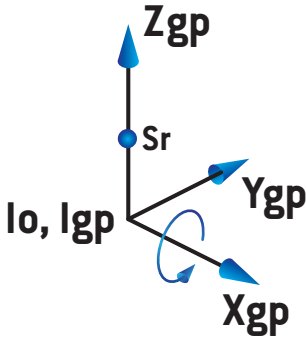

Figure 10. The gantry pitch coordinate system.

The X-ray image receptor coordinate system (Figure 11) has the gantry pitch coordinate system as its mother system and is a rotation about the z-axis of the gantry pitch coordinate system. When the X-ray image receptor angle is zero, the X-ray image receptor coordinate system coincides with the gantry pitch coordinate system. The positive rotation direction is counter-clockwise when viewed from a point on the positive z-axis facing towards the origin. S_r is the imager radiation source.

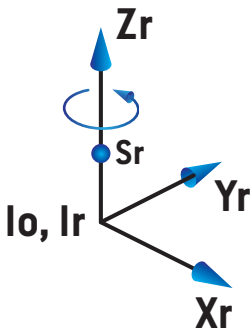

Figure 11. The X-Ray image receptor coordinate system.

Setup imaging systems and setup imagers

In RayStation a setup imaging system consists of one or several setup imagers. Each setup imager is an image radiation source with an associated image receptor. Setup imagers can be gantry-mounted or fixed in the treatment room.

Gantry-mounted setup imagers

A gantry-mounted imager moves with a gantry (treatment gantry or imaging gantry). A gantry-mounted imager can have a gantry angle offset.

A gantry-mounted imager only has a gantry rotation, i.e., the X-ray image receptor coordinate system coincides with the gantry coordinate system. The gantry rotation is given by the gantry angle of the beam or setup beam plus the imager gantry angle offset.

Fixed setup imagers

A fixed imager is fixed in the treatment room. A fixed imager can have all three rotations, i.e., gantry rotation, gantry pitch rotation and X-ray image receptor rotation.

5.4 THE JAW AND MLC LABELING STANDARD

In RayStation v2025 the jaws can be labeled according to one of the standards IEC 61217 or IEC 601-2-1. The description in this section uses the IEC 61217 Field coordinate system definitions setting.

5.4.1 The IEC 61217 jaw labeling standard

In **IEC 61217**, Y2 is close to the gantry and Y1 is away from the gantry, X1 is to the left and X2 to the right for an observer facing the gantry with gantry and collimator angle zero in the IEC 61217 coordinate system.

Gantry irradiating
from above

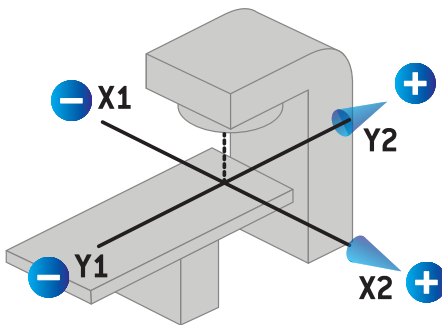

Figure 12. The jaw and MLC labels (IEC 61217).

5.4.2 The IEC 601 jaw labeling standard

In **IEC 601**, X1 is close to the gantry and X2 is away from the gantry, Y2 is to the left and Y1 to the right for an observer facing the gantry with gantry and collimator angle zero in the IEC 61217 coordinate system.

Gantry
irradiating from
above

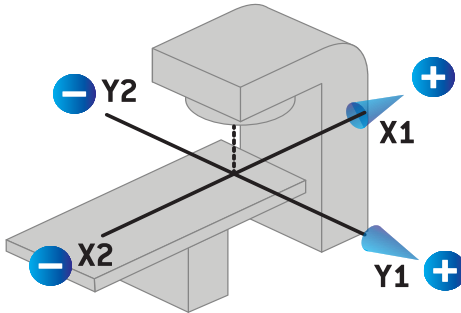

Figure 13. The jaw and MLC labels (IEC 601).

Note: *The jaw labeling standard setting only affects the names of the collimators in RayStation and the Machine properties workspace in RayPhysics. Note that the coordinate axes are still labeled according to IEC 61217, examples being the dose curve labels and parameters in the Beam model workspace in RayPhysics.*

6 SYSTEM INTEGRITY AND SAFETY

This chapter describes the relevant processes related to system integrity and safety.

There is no need for the user to edit, add or remove parts of the system data. All modifications shall be performed by specially trained service personnel. Service personnel can assist in adjusting the system according to local IT policies. For guidelines on how to set up and maintain required and recommended security controls for RayStation, see the *RSL-P-RS-CSG, RayStation Cyber Security Guidelines*.

System security alerts may be issued if RaySearch becomes aware of security vulnerabilities. Security alerts can be found in RayCommunity (the RaySearch online user community).

In this chapter

This chapter contains the following sections:

6.1	Protection against unauthorized use	p. 154
6.2	Backup routines and database maintenance	p. 154
6.3	Database access permissions	p. 155
6.4	ECC RAM	p. 155
6.5	System decommissioning	p. 156

6.1 PROTECTION AGAINST UNAUTHORIZED USE

The table below lists the various protection types in RayStation v2025.

Protection type	Description
Password protection	All operating system user accounts must be password protected to prevent unauthorized access to the system and databases.
Network security	The risk of unauthorized network access needs to be assessed by the user organization. It is recommended to use security best practices to protect the integrity of the environment, for example, use of a fire-wall on the network and regular security patching of the computers.
Protection against unauthorized physical access	The risk of unauthorized physical access to an unattended session needs to be assessed by the user organization. It is recommended to use session time-out which can be set by the user using features of the Windows Active Directory.
Virus protection	State-of-the-art virus protection shall be enabled for all parts of the system including the entire computer network if present. This shall include automatic updates or similar to keep the protection up-to-date.
License protection	RayStation v2025 uses a hardware-based license protection system to prohibit usable copies of the system to be made.
Databases and checksums	To prohibit use of program or data files not belonging to the installed version of RayStation v2025, the files are protected from exchange using checksums. The database design prevents modification of data storage other than using RayStation v2025 programs. The checksums on physics data files prevents modification of the files, or the application will not start.
Operating system administrator privileges	Tools enabling direct access to data stored in the databases shall be set up so as to require operating system administrator privileges.
Program code protection	RayStation v2025 program code and data shall only be accessed and modified as described in the manuals. Do not tamper with program code or data!

6.2 BACKUP ROUTINES AND DATABASE MAINTENANCE

Database backup and restore shall be performed using a standard SQL database management tool. It is recommended that all RayStation v2025 databases are set to recovery model full. This option makes it possible to run frequent backups and minimizes the risk of losing data in a database crash.

Maintenance type	Description
Regular backups	<p>Regular backups of all RayStation databases should be scheduled and the success of these backups should be verified on a regular basis.</p> <ul style="list-style-type: none"> • Full backups: We recommend that full backups are performed as often as time, space and system usage allows. • Differential backups: We recommend that differential backups are performed as often as time, space and system usage allows. • Transaction Log Backups: We recommend that Transaction Log Backups are performed on an hourly basis – but the frequency can be increased or decreased based on the specific clinic needs. <p>It is recommended to bring a database backup off-site on a daily basis.</p>
SQL Server OS maintenance	We recommend that the fragmentation on drives hosting the SQL data files should be checked for defragmentation. Where defragmentation is required this should be performed during maintenance windows.
Indexing	With additions, edits and changes to patient plans, the databases (particularly the Patient Database) can become fragmented. We recommend that an additional task to re-organize the databases is included in the database maintenance plan at an appropriate time (e.g., immediately following a full backup once a week).
Statistics	Updating statistics is important to ensure that queries compile with up-to-date statistics. We recommend setting the databases to <code>AUTO_CREATE_STATISTICS ON</code> and scheduling an update statistics task along with the re-indexing process to keep the statistics up-to-date as the data stored in the databases change.
Certificate and master key backup	SQL server certificates and master key are essential for database encryption. If a certificate or master key is lost, all data in the database is lost. Therefore, the SQL server certificate and the master key must be backed up before a database is encrypted.

6.3 DATABASE ACCESS PERMISSIONS

The default permissions for database access are set to the active directory group *RayStation-Users*. This group can be changed using the RayStation Storage Tool. The recommendation is to use a specific group that includes only RayStation users.

6.4 ECC RAM

An Error-correcting code memory (ECC RAM) is required for CPU memory. This is a type of computer data storage that can detect and correct the most common kinds of internal data corruption.

6.5 SYSTEM DECOMMISSIONING

RayStation stores personal and health-related data. When decommissioning a system, contact RaySearch support if needed to make sure that all storage locations for such data are identified.

A DEFINITIONS

Term	Meaning
BEV	Beam's Eye View
CBCT	Cone Beam Computed Tomography
CT	Computed Tomography
DCR	Digitally Composited Radiograph
DICOM	International standard to transmit, store, retrieve, print, process, and display medical imaging information
DVH	Dose Volume Histogram
deg	When the term deg is seen in RayStation v2025 this refers to degrees
DMLC	Dynamic Multi-Leaf Collimator
DRR	Digitally Reconstructed Radiograph
EUD	Equivalent Uniform Dose
External ROI	The ROI used to define patient outline. Defines the region used for dose computation, together with BOLUS for beam, SUPPORT and FIXATION ROIs.
FoR	Frame of Reference
GUI	Graphical User Interface
HDR	High Dose Rate
IMRT	Intensity Modulated Radiation Therapy
LEM	Local Effect Model
LET	Linear Energy Transfer
LET _d	Dose-averaged LET
LINAC	Linear accelerator, conventional radiation therapy treatment unit.
LS	Line Scanning
Light ions	Carbon and helium ions
MBS	Model-Based Segmentation

Term	Meaning
MCO	Multi-Criteria Optimization
MKM	Microdosimetric Kinetic Model
MU	Monitor Units
NP	Number of Particles. For protons the MU fields are replaced with Number of particles (NP) if the machine has Primary Dosimetry Unit set to Number of Particles.
NTCP	Normal tissue complication probability
OAR	Organ at risk
P+ or PPLUS	Probability of complication-free tumor control
PBS	Pencil Beam Scanning
PHY	Physical dose
POI	Point of Interest
RBE	Relative Biological Effectiveness
RBE dose	RBE weighted dose is in RayStation and this manual referred to as RBE dose.
ROI	Region of Interest
ROI Geometry	The image set-specific geometric representation of an ROI
SMLC	Segmental Multi-Leaf Collimator
SOBP	Spread Out Bragg Peak
SSD	Source to Skin Distance/Source to Surface Distance
SUV	Standardized Uptake Value
SVD	Singular Value Decomposition
TCP	Tumor control probability
UI	User Interface
VMAT	Volumetric Modulated Arc Therapy



CONTACT INFORMATION



RaySearch Laboratories AB (publ)
Eugeniavägen 18C
SE-113 68 Stockholm
Sweden

Contact details head office

P.O. Box 45169
SE-104 30 Stockholm, Sweden
Phone: +46 8 510 530 00
Fax: +46 8 510 530 30
info@raysearchlabs.com
www.raysearchlabs.com

RaySearch Americas

Phone: +1 347 477 1935

RaySearch China

Phone: +86 137 0111 5932

RaySearch India

E-mail:
manish.jaiswal@raysearchlabs.com

RaySearch Singapore

Phone: +65 8181 6082

RaySearch Australia

Phone: +61 411 534 316

RaySearch France

Phone: +33 (0)1 76 53 72 02

RaySearch Japan

Phone: +81 (0)3 44 05 69 02

RaySearch UK

Phone: +44 (0)2039 076791

RaySearch Belgium

Phone: +32 475 36 80 07

RaySearch Germany

Phone: +49 (0)172 7660837

RaySearch Korea

Phone: +82 01 9492 6432

