

RAYPLAN 12A SP1

Instructions for Use

12A



RayPlan
RayStation

Traceback information:
Workspace Minor updates 2 version a12
Checked in 2023-08-15
Skribenta version 5.6.013

Declaration of conformity



Complies with Medical Device Regulation (MDR) 2017/745. A copy of the corresponding Declaration of Conformity is available on request.

Safety notices

This user documentation contains WARNINGS concerning the safe use of the product. These must be followed.



WARNING!

The general warning sign informs you of a risk for bodily harm. In most cases the risk is related to mistreatment of the patient.

Note: *The note gives additional information concerning a specific topic, for example, things to consider when performing a certain step in an instruction.*

Copyright

This document contains proprietary information that is protected by copyright. No part of this document may be photocopied, reproduced or translated to another language without prior written consent of RaySearch Laboratories AB (publ).

All Rights Reserved. © 2022, RaySearch Laboratories AB (publ).

Printed material

Hard copies of Instructions for Use and Release Notes related documents are available upon request.

Trademarks

RayAdaptive, RayAnalytics, RayBiology, RayCare, RayCloud, RayCommand, RayData, RayIntelligence, RayMachine, RayOptimizer, RayPACS, RayPlan, RaySearch, RaySearch Laboratories, RayStation, RayStore, RayTreat, RayWorld and the RaySearch Laboratories logotype are trademarks of RaySearch Laboratories AB (publ)*.

Third-party trademarks as used herein are the property of their respective owners, which are not affiliated with RaySearch Laboratories AB (publ).

RaySearch Laboratories AB (publ) including its subsidiaries is hereafter referred to as RaySearch.

* Subject to registration in some markets.

TABLE OF CONTENTS

1	INTRODUCTION	7
1.1	About this manual	8
1.2	RayPlan system main applications	9
1.3	RayPlan documentation	9
1.3.1	RayPlan system documentation	9
1.3.2	Other associated documentation	10
2	PRODUCT INFORMATION	11
2.1	Intended use	12
2.2	Intended user	12
2.3	Intended patient population and medical conditions	12
2.4	Contraindications	12
2.5	Hardware and operating system	12
2.6	Manufacturer contact information	13
2.7	Reporting of incidents and errors in system operation	13
2.8	Regulatory representatives	13
2.9	Accuracy of dose computations	16
2.9.1	Accuracy for the photon dose engines	16
2.9.2	Accuracy for the electron dose engine	19
2.9.3	Accuracy for the brachytherapy TG43 dose engine	19
2.10	Product label	20
2.11	Lifetime	21
2.12	Regulatory information	22
3	INFORMATION NEEDED FOR SAFE OPERATION	23
3.1	Safety precautions	24
3.1.1	Warnings concerning user responsibility	25
3.1.2	Warnings concerning installation	31
3.1.3	Warnings concerning general system use	32
3.1.4	Warnings concerning DICOM import	33
3.1.5	Warnings concerning DICOM export	35
3.1.6	Warnings concerning dose computation	37
3.1.7	Warnings concerning patient modeling	46
3.1.8	Warnings concerning treatment planning	47
3.1.9	Warnings concerning TomoHelical and TomoDirect planning	49
3.1.10	Warnings concerning CyberKnife treatment planning	51
3.1.11	Warnings concerning brachytherapy treatment planning	51
3.1.12	Warnings concerning dose evaluation	54
3.1.13	Warnings concerning beam commissioning	56
3.1.14	Warnings concerning QA	60

3.1.15	Warnings concerning RayPlan Storage Tool	61
3.2	Import of patient data	62
3.3	Input data	62
3.4	Display format	62
4	INSTALLATION INSTRUCTIONS	63
4.1	Installation manual	64
4.2	System environment acceptance test	64
4.3	Hardware diagnostics checks	64
4.4	Data communication environment	64
5	DISPLAY OF COORDINATES, MOVEMENTS AND SCALES	65
5.1	The patient coordinate system	66
5.2	Patient coordinate system in the DICOM export	67
5.3	The treatment machine coordinate system	68
5.3.1	The machine coordinate systems overview	69
5.3.2	The gantry coordinate system	70
5.3.3	The beam limiting device coordinate system	70
5.3.4	The wedge filter coordinate system	74
5.3.5	The patient support coordinate system	75
5.3.6	The table top eccentric coordinate system	76
5.3.7	The table top coordinate system	76
5.3.8	The CyberKnife radiation source coordinate system	77
5.3.9	Dose curve coordinate system in RayPlan Physics	81
5.3.10	Setup imager coordinate systems	81
5.4	The jaw and MLC labeling standard	83
5.4.1	The IEC 61217 jaw labeling standard	83
5.4.2	The IEC 601 jaw labeling standard	84
6	SYSTEM INTEGRITY AND SAFETY	85
6.1	Protection against unauthorized use	86
6.2	Backup routines and database maintenance	86
6.3	Database access permissions	87
6.4	ECC RAM	87
6.5	System decommissioning	87
	APPENDIX A - DEFINITIONS	89
	INDEX	91

1 INTRODUCTION

About RayPlan

RayPlan is a pre-determined configuration of RayStation. It supports the full range of treatment planning activities for 3D-CRT, SMLC, DMLC, VMAT, TomoTherapy and electron beam radiation therapy. RayPlan also supports treatment planning for HDR brachytherapy.

RayPlan is compatible with all linear accelerators commercially available.

In this chapter

This chapter contains the following sections:

1.1	About this manual	p. 8
1.2	RayPlan system main applications	p. 9
1.3	RayPlan documentation	p. 9

1.1 ABOUT THIS MANUAL

This manual contains general product information, safety-related information, installation instructions, information about coordinate systems and machine scales and information about system integrity and safety. Study this manual carefully before using the RayPlan 12A system. Proper functioning of the device can only be guaranteed if the instructions in this manual are adhered to. Study the *RSL-D-RP-12A-RN*, *RayPlan 12A SP1 Release Notes* carefully, these notes provide final instructions on how to use the RayPlan 12A system.

Some modules described in this manual are not included in the standard configuration of RayPlan 12A and may require additional licenses.

1.2 RAYPLAN SYSTEM MAIN APPLICATIONS

The RayPlan system consists of the following main applications:



RayPlan – the main application where all the activities associated with treatment planning can be performed.

The RayPlan application is described in *RSL-D-RP-12A-USM, RayPlan 12A User Manual*.



RayPlan Physics – the beam commissioning application where activities such as beam commissioning, CT commissioning and beam 3D modeling activities can be performed.

The RayPlan Physics application is described in *RSL-D-RP-12A-RPHY, RayPlan 12A RayPlan Physics Manual*.



Clinic Settings – the clinic settings administration tool.

The Clinic Settings application is described in *RSL-D-RP-12A-USM, RayPlan 12A User Manual*.



RayPlan Storage Tool – the database administration tool.

The RayPlan Storage Tool application is described in *RSL-D-RP-12A-USM, RayPlan 12A User Manual*.

1.3 RAYPLAN DOCUMENTATION

1.3.1 RayPlan system documentation

The RayPlan 12A system documentation consists of:

Document	Description
<i>RSL-D-RP-12A-IFU, RayPlan 12A SP1 Instructions for Use</i>	This manual contains regulatory information and safety information concerning the RayPlan 12A system.
<i>RSL-D-RP-12A-RN, RayPlan 12A SP1 Release Notes</i>	This document provides a summary of new features, known issues and changes since the previous version of RayPlan.
<i>RSL-D-RP-12A-USM, RayPlan 12A User Manual</i>	This manual describes the functionality of the RayPlan 12A system and gives step-by-step instructions on how to perform the most common operations.
<i>RSL-D-RP-12A-RPHY, RayPlan 12A RayPlan Physics Manual</i>	This manual describes the RayPlan Physics application.
<i>RSL-D-RP-12A-REF, RayPlan 12A Reference Manual</i>	This manual contains algorithm descriptions and physics reference information.
<i>RSL-D-RP-12A-OPT, RayPlan 12A A Guide to Optimization in RayPlan</i>	This manual contains detailed information about optimization in RayPlan 12A.

Note: *In the case of a service pack, only the affected manuals will be updated. For a complete list of the manuals that have been updated in the service pack, refer to the RayPlan release notes for that specific service pack.*

1.3.2 Other associated documentation

- *RSL-D-RP-12A-SEAT, RayPlan 12A System Environment Acceptance Test Protocol*
- *RSL-D-RP-12A-BCDS, RayPlan 12A Beam Commissioning Data Specification*
- *RSL-D-RP-12A-DCS, RayPlan 12A DICOM Conformance Statement*
- *RSL-D-RP-12A-SEG, RayPlan 12A System Environment Guidelines*
- *RSL-D-RP-12A-ATP, RayPlan 12A Product Acceptance Test Protocol*
- *RSL-D-RP-12A-SUO, RayPlan 12A System Upgrade Options*
- *RSL-D-RP-12A-CIRSI, RayPlan 12A Customer Instruction for RayPlan Installation*
- *RSL-P-RS-CSG, RayPlan Cyber Security Guidance*

2 PRODUCT INFORMATION

This chapter describes important information about the RayPlan 12A system.

In this chapter

This chapter contains the following sections:

2.1	Intended use	p. 12
2.2	Intended user	p. 12
2.3	Intended patient population and medical conditions	p. 12
2.4	Contraindications	p. 12
2.5	Hardware and operating system	p. 12
2.6	Manufacturer contact information	p. 13
2.7	Reporting of incidents and errors in system operation	p. 13
2.8	Regulatory representatives	p. 13
2.9	Accuracy of dose computations	p. 16
2.10	Product label	p. 20
2.11	Lifetime	p. 21
2.12	Regulatory information	p. 22

2.1 INTENDED USE

RayStation is a software system for radiation therapy and medical oncology. Based on user input, RayStation proposes treatment plans. After a proposed treatment plan is reviewed and approved by authorized intended users, RayStation may also be used to administer treatments.

The system functionality can be configured based on user needs.

Japan: For the intended use in Japan, refer to RSJ-C-00-03 Japanese regulatory IFU for RayStation.

2.2 INTENDED USER

The intended users of RayStation shall be clinically qualified staff trained in using the system.

The users must have a working knowledge of English or another user interface language provided.

2.3 INTENDED PATIENT POPULATION AND MEDICAL CONDITIONS

The intended patients for RayStation are patients where a qualified and licensed medical practitioner has decided it is appropriate to give radiation therapy or medical oncology treatment for tumors, lesions and other conditions.

2.4 CONTRAINDICATIONS

The user is responsible for determining the individual treatment plan and techniques for each patient and this also includes identifying any contraindications for the individual treatment.

2.5 HARDWARE AND OPERATING SYSTEM

RayPlan 12A shall be installed on a high end PC with a recommended screen resolution of 1920 x 1200 pixels (or 1920 x 1080). RayPlan 12A can be used with different versions of Windows operating systems. For details about recommended hardware and OS setups, see *RSL-D-RP-12A-SEG, RayPlan 12A System Environment Guidelines*.

The system must only be used with a computer approved to applicable hardware safety standards with respect to electric failure and electromagnetic radiation.

It is recommended to install new Windows Service Packs. These are tested, cumulative sets of security and critical updates widely released by Microsoft. Also, the Security Updates, which are widely released fixes for operating system security-related vulnerabilities are recommended to install. It is discouraged from installing any other updates. After all updates, system performance must be verified, see *section 4.2 System environment acceptance test on page 64*.

Microsoft SQL Server

It is recommended to install new SQL server service packs. These are released and tested by Microsoft and include cumulative sets of hotfixes and fixes to reported issues. After all updates, system performance must be verified (see *section 4.2 System environment acceptance test on page 64*).

GPUs used for computations

GPUs used for computation must have ECC RAM and the ECC state must be enabled in the GPU driver settings. Deformable image registration may be computed on GPUs without ECC RAM. The version

of the GPU drivers, identified in the System Environment Guidelines, must be used at all times. If multiple GPUs are used for computations, it is recommended that all are of the same model. If multiple GPUs of different models are used, consecutive computations may not give identical results, depending on which graphics card(s) have been used. For a detailed list of supported graphics cards, refer to the *RSL-D-RP-12A-SEG, RayPlan 12A System Environment Guidelines*. Additional validations have been performed and are identified with certificates available from support@raysearchlabs.com.

2.6 MANUFACTURER CONTACT INFORMATION

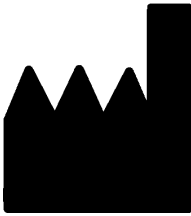

RaySearch Laboratories AB (publ)
Eugeniavägen 18C
SE-113 68 Stockholm
Sweden
Telephone: +46 8 510 530 00
E-mail: info@raysearchlabs.com
Country of origin: Sweden

2.7 REPORTING OF INCIDENTS AND ERRORS IN SYSTEM OPERATION

Report incidents and errors to the RaySearch support email: support@raysearchlabs.com or to your local support organization via telephone.

Any serious incident that has occurred in relation to the device must be reported to the manufacturer.

Depending on applicable regulations, incidents may also need to be reported to national authorities. For the European Union, serious incidents must be reported to the competent authority of the European Union Member State in which the user and/or patient is established.

2.8 REGULATORY REPRESENTATIVES

The table below describes the regulatory representatives and their contact information.

Regulatory representatives	Contact information
Australian Sponsor	Emergo Australia Level 20, Tower II Darling Park 201 Sussex Street Sydney, NSW 2000 Australia

Regulatory representatives	Contact information
Brazil Importer	Emergo Brazil Import Importação e Distribuição de Produtos Médicos Hospitalares Ltda. Avenida Francisco Matarazzo, 1752, sala 502 e 503, Água Branca, São Paulo, SP CEP:05.001-200. CNPJ:04.967.408/0001-98 Email: brazilvigilance@ul.com Responsável Técnico: Luiz Levy Cruz Martins – CRF/SP: 42415 Anvisa nº: 80117580996
Chinese representative	RaySearch (Shanghai) Medical Device Co., Ltd Room 605, No. 1118, Pudong South Road Pilot Free Trade Zone, Shanghai China
Hong Kong representative	Emergo Hong Kong Limited 6/F, 100QRC 100 Queen's Road Central Hong Kong
Israeli representative	I.L Emergo Israel Ltd. Andrei Sakharov 9 Matam Park Haifa 3508409 P.O.B. 15054 Haifa 3190501 Israel
Japanese representative	RaySearch Japan K.K. Saiwai building, 1-3-1 Uchisaiwaicho Chiyoda-ku Tokyo 100-0011 Japan
Korean representative	RaySearch Korea, LLC 11F, Sin-il Building 131 oegye-ro (Chungmu-ro-2-ga) Jung-gu, Seoul, P.O. Box 04537 Korea
New Zealand Sponsor	CARSL Consulting PO Box 480 Pukekohe New Zealand

Regulatory representatives	Contact information
Singapore representative	RaySearch Singapore Pte. Ltd. 260 Orchard Road #07-01/04 The Heeren, Singapore 238855 Singapore
Taiwanese representative	Tomorrow Medical System Co., Ltd. 6F, No. 366, Chang Chun Road Taipei, 104 Taiwan
Thai representative	Kamol Sukosol Electric Co., Ltd. 665 Mahachai Road, 2nd Floor Samranraj, Pranakorn Bangkok 10200 Thailand
US Agent	RaySearch Americas, Inc. The Empire State Building 350 5th Avenue, Suite 5000 New York, New York 10118 USA

2.9 ACCURACY OF DOSE COMPUTATIONS

All dose engines in RayPlan 12A have been verified to be at the same level of accuracy as that of independent well-renowned treatment planning systems. Dose computations must still be validated by the user for all clinically relevant situations, refer to *section 3.1.1 Warnings concerning user responsibility on page 25* for more information.

Note: *RayPlan beam models are general with respect to machine type and properties. It may be possible to create beam models for treatment machine setups that have not been explicitly validated by RaySearch.*

2.9.1 Accuracy for the photon dose engines

RayPlan has two photon dose engines: collapsed cone and Monte Carlo. The validation strategies for the two dose engines are described below, followed by a description of the validation scope for different machines and treatment techniques. The Monte Carlo dose engine does not support TomoTherapy machines.

Validation strategy for the collapsed cone photon dose engine

RayPlan validation has been performed against a substantial set of measurements including point doses in homogeneous and heterogeneous phantoms, line doses, film and measurements using the Delta4, MapCheck, ArcCheck, MatriXX, Octavius1500 and PTW 729 detectors. This includes the IAEA test suite, which includes measured doses for an Elekta machine for a number of test cases for energies 6 MV, 10 MV and 18 MV¹. The acceptance criteria of the validations against measurements are formulated in terms such as the gamma criterion (pass if the gamma value is below 1 for 95% of the data points for gamma 3%, 3 mm), point dose differences and confidence levels¹. The overall accuracy is acceptable. Some algorithm limitations have been identified and are described in this section, in the warning 4001 in *section 3.1.1 Warnings concerning user responsibility on page 25* and in the Algorithm weaknesses section in *RSL-D-RP-12A-REF, RayPlan 12A Reference Manual*.

The collapsed cone photon dose engine in RayPlan 12A has also been compared to classical well-renowned treatment planning systems, such as Eclipse (Varian), Pinnacle³ Radiation Treatment Planning System 7.2 (Philips), Monaco (Elekta) and Oncentra (Elekta). The comparison includes plans for Siemens, Elekta and Varian machines. Agreement between the dose computed by the independent treatment planning systems and the RayPlan dose is defined to mean that the global gamma² value is below 1 for 95% of the volume for gamma criterion (3%, 3 mm), and for 98% of the volume for gamma criterion (5%, 5 mm). Since all cases return gamma distributions within the acceptance criteria, the dose engine computations can be regarded as equivalent to the clinical systems to which they were compared.

¹ IAEA-TECDOC-1540, Specification and Acceptance Testing of Radiotherapy Treatment Planning Systems, April 2007.

² Low D.A., Harms W.B., Mutic S, and Purdy J.A., A technique for the qualitative evaluation of dose distributions, Med. Phys. 25 (1998) 656-661.

The validation has focused on typical clinical usage, with common LINAC models such as Varian (600 CD, CLINAC, 2100, 2100 EX, 2300C/D, Trilogy, TrueBeam with MLCs MLC120, HD120, Millennium MLC, m3 and Varian Halcyon), Elekta (with MLCi/MLCi2, Beam Modulator and Agility heads), and Siemens (Primus with 3D-MLC and Artiste), for energies between 4 MV and 20 MV, and water phantoms and patient geometries. Flattening filter free delivery is validated using Siemens Artiste and Varian Halcyon. Most data is collected using MLCs with leaf widths of 5 mm and 10 mm. RayPlan 12A has also been validated with the Brainlab m3 add-on MLC on a Varian Novalis machine. The m3 MLC has not been validated with any other machine, for example a machine without backup jaw such as the Siemens machines. No other add-on MLC has been validated.

Validation for wedges, blocks and cones

For wedges the validation is performed solely in water. The validation is focused on central square fields with a few exceptions. Special care should be taken when verifying and evaluating wedge beam models. Block validation is performed by comparing RayPlan 12A to Eclipse (Varian) and Oncentra (Elekta) returning gamma distributions within the acceptance criteria and as part of the IAEA test suite. The IAEA test suite also includes Elekta wedges. Only divergent photon blocks are supported. Cone validation is limited to Elekta LINACs.

Dose calculation for rotational plans

Standard VMAT delivery technique has been validated for Varian, Elekta and Vero LINACs. Sliding window VMAT sequencing is supported for Elekta Agility, Elekta MLCi2 and Varian. VMAT sequencing should be considered on par with a new treatment technique and therefore beam model and machine behavior validation, and per-patient QA must be performed.

The validation has shown that the RayPlan dose calculation for small field rotational plans is highly sensitive to beam model MLC parameters.

RayPlan 12A offers the VMAT burst mode technique, where every second segment contains MLC motion without beam on and every other segment has beam on without MLC motion. The burst mode technique is only intended and validated for Siemens machines.

Dose calculation for Vero

For RayPlan 12A, validation for the Vero machine has been performed. The CC dose engine has been successfully validated in comparison to measurements for static MLC and VMAT plans.

Dynamic IMRT (DMLC) for Vero has not been validated and DMLC is not available for Vero machines in RayPlan 12A. The Vero validation is limited to the Vero MLC with 30 leaf pairs with all leaf widths 0.5 cm. Dynamic tracking delivery has not been part of the RayPlan 12A validation. It is up to the user to validate the delivered dose for Vero plans with dynamic tracking enabled.

Dose calculation for CyberKnife

RayPlan 12A dose calculation has been validated for CyberKnife M6/S7 treatment machines. Older CyberKnife versions are not supported by RayPlan 12A.

The collapsed cone dose engine has been successfully validated in comparison with measurements for treatment plans collimated with fixed cones, iris cones and MLC. Measurements have been performed with film and ion chamber, in different homogeneous and heterogeneous phantoms, for

example the CIRS lung phantom. The validation includes different node sets and motion synchronization techniques.

The selected motion synchronization technique does not have any effect on the computed dose in RayPlan. For accuracy of target tracking using motion synchronization techniques available for the CyberKnife treatment machine, refer to Accuray.

In addition to comparison with measurements, RayPlan dose has been compared with dose computed by the Accuray dose engines Finite Size Pencil Beam (FSPB) and Monte Carlo, showing excellent agreement.

Validation strategy for the photon Monte Carlo dose engine

The photon Monte Carlo dose engine uses the same fluence computation in the LINAC head as the collapsed cone dose engine. The description of MLC details, blocks, cones, virtual wedges and physical wedge transmission has been validated thoroughly in combination with the collapsed cone dose engine. The same fluence computation has been validated also in combination with the Monte Carlo dose computation using a representative subset of the measurements from the collapsed cone dose computation. The subset is selected to cover different energies (4 MV to 20 MV), LINAC models (Varian with MLC120, HD120 and m3, Elekta with MLC Agility and MLCi/i2 and CyberKnife), wedges (Varian standard wedge, EDW and Elekta motorized wedge), cones and blocks, treatment techniques (3D-CRT, SMLC, DMLC and arc treatments) and homogenous and heterogeneous geometries. The IAEA test suite (Elekta 6 MV, 10 MV, 18 MV) was included and a high resolution AAPM TG105 test suite (TrueBeam with 6 MV, 10 MV, 10 MV FFF) with heterogeneous inserts for different geometries (slabs, inclined incidence, nose-shaped surfaces, steps) in water was added compared to the collapsed cone dose validation.

Measurements included scanned profiles, depth doses and point measurements in water and in the CIRS phantom, and Delta4, ArcCheck and MapCheck measurements. The acceptance criteria were the same as the ones used for the collapsed cone validation and the overall accuracy was acceptable. Most limitations described in *section 2.9.1 Accuracy for the photon dose engines on page 16* also apply for the photon Monte Carlo dose engine. For details see *RSL-D-RP-12A-REF, RayPlan 12A Reference Manual*. See also warning 4001 in *section 3.1.1 Warnings concerning user responsibility on page 25*.

In addition to the measurement based validation, the photon Monte Carlo computation in patient has been cross-checked against EGSnrc for different geometries (slabs, off-axis heterogeneous inserts, curved surfaces), materials (water, lung, bone, aluminum, titanium), energies (0.5 MeV to 20 MeV) and fields sizes (0.4 cm x 0.4 cm to 40 cm x 40 cm). Since the measurement uncertainty is no longer present, the acceptance criteria in the validation tests using simulated dose are stricter than those for measurement; 95% of all voxels are required to have a gamma value below 1 for gamma 2%, 2mm.

The Monte Carlo dose engine does not support TomoTherapy machines. The computation has not been validated for Vero and Siemens LINACs. It is up to the user to validate RayPlan 12A Monte Carlo dose computation with Vero and Siemens machines.

2.9.2 Accuracy for the electron dose engine

The electron Monte Carlo dose engine in RayPlan 12A has been compared to the Oncentra (Elekta) treatment planning system using the same gamma criteria as for photons. The comparison with Oncentra includes plans for an Elekta Synergy machine. Since all cases return gamma distributions within the acceptance criteria, the electron dose computations can be regarded as equivalent to the clinical system to which it was compared.

In addition, the electron dose engine in RayPlan 12A has been compared to measurements for treatment machines with x and y jaws (Elekta and Varian), Elekta machines with Beam Modulator and machines without x jaws (Elekta Agility and Siemens).

The electron Monte Carlo dose computation in patient has also been cross-checked against EGSnrc for different geometries, materials and energies.

The RayPlan 12A system has been validated for typical clinical usage of applicator with cutout collimated fields. Only Cerrobend cutouts with straight edges, i.e. parallel to the beam axis line, are supported and validated.

2.9.3 Accuracy for the brachytherapy TG43 dose engine

The brachytherapy TG43 dose engine has been validated against published QA along-away data for six common HDR sources, including the E&Z Bebig Co0-A86 and Ir2.A85-2 sources. The acceptance criteria are formulated in terms of local gamma criteria and relative dose differences. All six sources pass the acceptance criteria.

The dose engine has also been validated against clinical independent treatment planning systems, implementing the TG43 formalism (SagiPlan, E&Z Bebig and Oncentra Brachy, Elekta). The validation is performed both for single dwell positions in a phantom and treatment plans for cervix, prostate and breast treatments. Additionally, it has been compared to an independent Monte Carlo dose engine (EGS Brachy) for a relevant patient case. Local gamma criteria are used for comparison to the independent systems. Since all cases return gamma distributions within the acceptance criteria, the brachytherapy TG43 dose computation performs equally well as the independent systems to which it was compared.

Validation has also been performed against the EQUAL-ESTRO laboratory measurement procedure. The measurement point passes the acceptance criterion formulated as a relative dose difference.

The overall accuracy of the RayPlan TG43 dose engine is in accordance with clinical standards. However, the TG43 formalism has intrinsically some limitations, which must be known by the user. The acceptance criteria and dose engine algorithm limitations are found in section *TG43 dose engine accuracy and limitations* in the *RSL-D-RP-12A-REF, RayPlan 12A Reference Manual*.

2.10 PRODUCT LABEL





The version number of an installed RayPlan 12A system can be found by choosing **Help: About RayStation** in the RayPlan menu.

The following information can be identified:

- Product name = RayStation
- **产品型号: RayStation** (for the Chinese market only)
- Release version = **13.1**
- Marketing name = RayPlan 12A SP1
- Software build number = **13.1.0.144**
- Clinical build = Indicates that the software is designed for clinical use.

Note: A clinical installation requires both a clinical build and a clinical license. Otherwise, 'Not for clinical use' will be displayed in the title bar.

- Product lifetime = The lifetime per market is one year after the next major release, but no less than three years
- Radiation treatment planning system software = The generic name of the product
- **产品名称: 放射治疗计划系统软件** (for the Chinese market only)
- **MD** = Indicates that the product is a medical device
- **UDI** = Unique Device Identification number
- **CH|REP** = The Swiss authorized representative and importer
- Driver information = The installed version for CyberKnife RAIL. Expand this field by clicking the arrow.

-  = The CE mark and the notified body number
-  = Production date
-  = Consult instructions for use
-  = The name and address of the manufacturer
-  = The support e-mail address

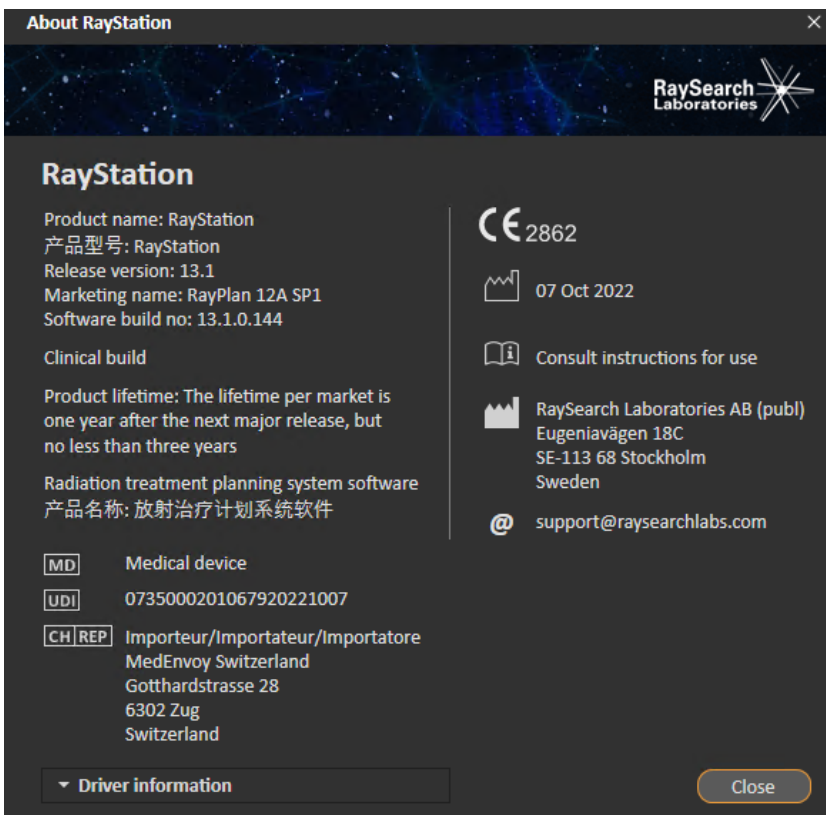

Figure 1. The **About RayStation** dialog for RayPlan.

2.11 LIFETIME

The lifetime per market is one year after the next major release, but no less than three years. Support for a product version in a market ends 36 months after market clearance, provided a new major version is released within 24 months. If not, support is prolonged and ends 12 months after the

next major version is released in that market. When a version is no longer supported in a given market, it is considered to be end of life in that market.

2.12 REGULATORY INFORMATION

Disclaimer

Japan: For the regulatory information in Japan, refer to RSJ-C-02-003 Disclaimer for the Japanese market.

European SRN-number

The single registration number (SRN) = SE-MF-000001908 has been issued to RaySearch Laboratories AB (publ), as required by the EU MDR – Regulation (EU) 2017/745.

3 INFORMATION NEEDED FOR SAFE OPERATION

This chapter describes information needed for safe operation of the RayPlan 12A system.

Note: *Be aware that additional safety-related release notes may be distributed separately within a month of software installation.*

In this chapter

This chapter contains the following sections:

3.1	Safety precautions	p. 24
3.2	Import of patient data	p. 62
3.3	Input data	p. 62
3.4	Display format	p. 62

3.1 SAFETY PRECAUTIONS

Adhere to the following warnings for safe operation of the RayPlan 12A system.

In this section

This section contains the following sub-sections:

3.1.1	Warnings concerning user responsibility	p. 25
3.1.2	Warnings concerning installation	p. 31
3.1.3	Warnings concerning general system use	p. 32
3.1.4	Warnings concerning DICOM import	p. 33
3.1.5	Warnings concerning DICOM export	p. 35
3.1.6	Warnings concerning dose computation	p. 37
3.1.7	Warnings concerning patient modeling	p. 46
3.1.8	Warnings concerning treatment planning	p. 47
3.1.9	Warnings concerning TomoHelical and TomoDirect planning	p. 49
3.1.10	Warnings concerning CyberKnife treatment planning	p. 51
3.1.11	Warnings concerning brachytherapy treatment planning	p. 51
3.1.12	Warnings concerning dose evaluation	p. 54
3.1.13	Warnings concerning beam commissioning	p. 56
3.1.14	Warnings concerning QA	p. 60
3.1.15	Warnings concerning RayPlan Storage Tool	p. 61

3.1.1 Warnings concerning user responsibility

**WARNING!**

Ensure sufficient training. The user organization shall ensure that individuals authorized to perform treatment planning functions are appropriately trained for the functions they perform. Only individuals authorized to perform treatment planning functions and appropriately trained in treatment planning techniques should use this software. Carefully read all instructions prior to use. The user is responsible for proper clinical use and the prescribed radiation dose. (508813)

**WARNING!**

Input data quality. Always be aware that the quality of the output depends critically on the quality of the input data. Any irregularities in the imported data or uncertainties about input data units, identification, image orientation or quality of any other nature shall be thoroughly investigated before the data is used. (508811)

**WARNING!**

Plan review and approval. All treatment plan data shall be carefully reviewed and approved by a qualified person before it is used for radiotherapy treatment purposes. A plan (beam set) that is 'optimal' with respect to the optimization goals may still be inappropriate for clinical use. (508826, 508814)

**WARNING!**

Beam models must be validated before clinical use. It is the responsibility of the user to validate and commission all beam models before they are used to create clinical external beam radiotherapy treatment plans.

RayPlan is developed to be used by trained Radiation Oncology professionals. We strongly suggest that users adhere to recommendations published in AAPM TG40, TG142, TG53, TG135, IAEA TRS 430, IAEA TRS 483 and other standards to ensure accurate treatment plans.

Computed dose accuracy depends directly on the beam model quality. Beam model insufficiency may lead to deviations between approved and delivered dose. All parameter values and plan QA and QC shall be reviewed and approved by qualified physicists. The dose calculation must be validated for all commissioned CT machines.

- The computed dose shall be validated for all relevant clinical situations including, but not limited to, variation in SAD, SSD, field-size, field-shape, off-axis position (x, y and diagonal), collimation type, degree of modulation, leakage dose (variation in MU/Gy or NP/Gy), couch/gantry/collimator angles, CyberKnife node sets, patient/phantom material composition and patient/phantom material geometry.
- Known limitations are described in the *RSL-D-RP-12A-REF, RayPlan 12A Reference Manual*. Additional limits of operation for each beam model must be identified during validation and adhered to during planning.

For photons:

Special care should be taken before using RayPlan with MLC leaves smaller than 5 mm, materials that differ from common patient materials, blocks, small circular cones, wedges (in particular off-axis wedges), complex VMAT plans, rotational plans with small field sizes, Siemens mARC plans and wave arc plans, especially with larger ring rotation than 15 degrees.

Note that:

- a beam model validated for 3D-CRT is not necessarily suitable for IMRT plans.
- a beam model validated for SMLC is not necessarily suitable for DMLC plans.
- a beam model validated for SMLC or DMLC is not necessarily suitable for VMAT plans.
- a beam model validated for VMAT is not necessarily suitable for plans created using sliding window VMAT sequencing.
- a beam model commissioned for one photon dose engine (Collapsed Cone or Monte Carlo) is not suitable for the other dose engine without adaptation of the

beam model parameters.

Validation must be performed for each selected treatment technique using Beam 3D modeling or RayPlan. For C-arm and CyberKnife LINACs, see warning 9356 and 3438. For TomoTherapy treatment machines, see also warning 10172.

For electrons:

Validation must include relevant applicator geometries, field sizes without cutout, field sizes and field shapes with cutout, field shape orientations for rectangular applicators, cutout materials and thicknesses, air gaps to isocenter and D50 water ranges per nominal beam energy. Only Cerrobend cutouts with straight edges, i.e., parallel to the beam axis line, are supported.

[4001]



WARNING!

Brachytherapy models must be validated before clinical use. Brachytherapy source models and application setups must be validated before clinical use.

It is the responsibility of the user to validate all brachytherapy source models and application setups before clinical use, see warnings 283358, 283879 for more details.

[285635]

**WARNING!**

TomoTherapy machine commissioning. When commissioning a TomoTherapy machine, most parameters are read from iDMS and only minor changes are expected to be required in the machine model in RayPlan Physics. The transverse profile, jaw fluence output factors and leaf latency offsets are overwritten in this process and may need to be updated.

Note that for TomoTherapy machines the computed dose curves in the Beam commissioning module are normalized against the measured curves, i.e., the measured and computed dose curves will match in output regardless of the output of the beam model. The output of the model must therefore be adjusted and verified for all field widths using TomoHelical beams. For more information, refer to the *RSL-D-RP-12A-BCDS, RayPlan 12A Beam Commissioning Data Specification*.

Note also that the MLC filters are not part of the dose curve calculation in the Beam commissioning module in RayPlan Physics and their usage can only be verified using TomoHelical or TomoDirect beams.

The dose calculation must be validated for the relevant range of clinical treatment fields before clinical use. In addition to what is listed in warning 4001, validation shall include different jaw sizes and modes, projection times, opening fractions and pitches.

(10172)

**WARNING!**

Collision detection for CyberKnife. The collision detection performed in RayPlan does not guarantee that collisions are always detected. Before delivery, the user is obliged to validate that the delivery system will perform collision detection.

(339623)

**WARNING!**

Block/cutout verification. Always verify that the blocks and electron beam cutouts created in the Beam design modules are physically realizable. It is not possible to define any block manufacturing constraints in RayPlan.

Always check the created block against the block aperture printout. (508816)

**WARNING!**

Verify the scale of the block/cutout printout. The printer settings will affect the actual size of the block/cutout in the printout. Before using the block/cutout printout for block/cutout manufacturing or verification, always check that the scale of the x- and y-axes are equal and that 1 cm on the verification scale corresponds to 1 cm using a ruler. {508818}

**WARNING!**

ROI/POI verification. Always review all regions of interest (ROIs) and points of interest (POIs) carefully before using them for treatment planning or evaluation purposes. {508820}

**WARNING!**

Review 4DCT projections. The user shall review the resulting image set from a 4DCT projection before using it for treatment planning or evaluation purposes. The projected image set shall be compared against the image sets in the 4DCT group in order to verify that the Hounsfield Units and corresponding densities are as expected. This can be performed by examining HU values in the patient views and by computing evaluation doses in the Plan Evaluation module.

The geometrical properties of the projected image set, such as orientation, position and size shall also be compared against the original 4DCT. This can be performed by fusing the projected image sets with the original 4DCT image sets in the Structure Definition module or the Image Registration module and verify that they are aligned correctly. {117566}

**WARNING!**

Image specific density table obtained through HU rescaling. When using an image set specific density table obtained through HU rescaling it is highly important that the user reviews the resulting density table properly before using it for dose computation. The rescaled density table will directly affect the dose computation. {125272}



WARNING!

Patient setup. Couch shift (table top translation) instructions for positioning the patient are displayed in the Patient setup dialog and in the plan report.

The default couch shift presentation is "Patient", i.e., the couch shift instructions in the Patient setup dialog are expressed in terms of patient anatomical directions.

If desired, the couch shift presentation can be changed to "Couch", i.e., the couch shift instructions in the Patient setup dialog are expressed in couch directions. The couch shift presentation is changed in the Clinic Settings application.

Before clinical use, always verify that the couch shift displayed in RayPlan and in the plan report are as intended and in accordance with clinical practice.

Note that another option for patient setup is to export the couch shift according to the DICOM standard. This option can be selected in RayPlan Physics.

(9101)



WARNING!

Review frame-of-reference registration before dose computation. It is especially important that frame-of-reference registrations that have been imported are reviewed before computing dose on additional image sets. (360380)



WARNING!

Restricted sale in the U.S. Federal (U.S.) and State laws restrict the sale of this product to a physician or on a physician's order.

(4782)



WARNING!

Single sign-on setting. If the single sign-on setting is used in Clinic Settings, it is possible for an unauthorized user to authenticate in RayPlan if a workstation is left unattended. The authentication is done in the name of the logged in user.

(578762)

**WARNING!**

Verify accessory codes. Accessory codes can be entered for photon blocks and electron cutouts. The user must verify that the accessory code entered in RayPlan matches the physical accessory to be used during treatment. RayPlan will not automatically invalidate the accessory code if the block or cutout is modified in RayPlan. The block or cutout will not be invalidated in RayPlan if the accessory code is changed. It is the user's responsibility to ensure that the correct accessory code has been entered and, if necessary, updated.

(574934)

3.1.2 Warnings concerning installation**WARNING!**

Display settings. Be aware that the RayPlan system's visual output depends on monitor calibration, resolution and other hardware specific parameters. Ensure that the monitor output is appropriate for the clinical tasks. (366562)

**WARNING!**

Hardware/Software platform. The System Environment Acceptance Test shall be performed whenever the hardware or software platform is changed. (366563)

**WARNING!**

Installation tests. The user must add additional tests specific for the installation and configuration of the RayPlan system at the user organization. (366564)

**WARNING!**

Use of non-ECC GPU memory. GPUs used for computations must have ECC RAM and the ECC state must be enabled in the GPU driver settings. Deformable image registration may however be computed on GPUs without ECC RAM.

(8453)



WARNING!

Dose calculation on GPU may be affected by computer/driver updates. The dose calculation on GPU must be revalidated after any hardware or software platform changes, including operating system Service Packs. This can be done by running the *RSL-D-RP-12A-SEAT, RayPlan 12A System Environment Acceptance Test Protocol* and by running the self-tests for all computations using GPU.

(4039)

3.1.3 Warnings concerning general system use



WARNING!

Running multiple instances of RayPlan. Take extra care when running multiple instances of RayPlan. Always make sure that you are working on the correct patient.

(3312)



WARNING!

Independent dose calculation. Ensure that the independent dose calculation system that is used really is independent. There are systems that may appear to be suitable for independent dose calculation that are in fact not independent at all since the dose engine is manufactured by RaySearch and uses the same algorithm for photon dose computation and possibly also the same code as RayPlan (e.g., Compass (IBA)).

(6669)



WARNING!

Be careful when changing auto recovery mode. Auto recovery data is stored in a database or on disk. If the auto recovery mode is switched off or if the storage area is changed while there is still auto recovery data in the old storage place, that data is not useful anymore and may be impossible for RayPlan to delete. The data in the old storage place must be deleted manually.

(282521)

**WARNING!**

Report template naming. User-created report templates do not necessarily need to include all information about patient, plan, beamsets, etc. For example, a report template may only include the currently selected beam set. Use a clear naming convention when creating report templates. (5147)

**WARNING!**

Changed behavior for prescriptions for beam sets with background dose. From RayPlan 11A, prescriptions will always prescribe dose for the current beam set. Prescriptions defined in RayPlan versions prior to 11A relating to beam set + background dose are obsolete. Beam sets with such prescriptions cannot be approved and the prescription will not be included when the beam set is DICOM exported.

From RayPlan 11A, prescription percentage is no longer included in exported prescription dose levels. In RayPlan versions prior to 11A, the Prescription percentage defined in RayPlan is included in the exported Target Prescription Dose. This has been changed in version 11A so that only the Prescribed dose defined in RayPlan is exported as Target Prescription Dose. This change also affects exported nominal contributions.

In RayPlan versions prior to 11A, the Dose Reference UID exported in RayPlan plans was based on the SOP Instance UID of the RT Plan/RT Ion Plan. This has been changed so that different prescriptions can have the same Dose Reference UID. Because of that change, the Dose Reference UID of plans exported using RayPlan versions prior to 11A has been updated so that if the plan is re-exported, a different value will be used.

(344549)

3.1.4 Warnings concerning DICOM import

**WARNING!**

Image set integrity. DICOM provides no way of verifying that all image slices in an image series are included. The user must always verify this manually after import. (508830)



WARNING!

Imported dose. An imported dose for an approved plan will automatically be considered clinical. {508831}



WARNING!

For imported dose, no assumptions on how the dose was calculated are made.

The dose will not be invalidated when data that is used for calculating dose in RayPlan is different from the data the imported dose was calculated on. This applies even if the imported dose was originally calculated in RayPlan. For example, if the structure set is modified with density overrides or with changes to the External ROI, the imported dose will not be invalidated.

{224134}



WARNING!

Fractionation scheme is discarded in DICOM import. When a DICOM plan is imported to RayPlan the fractionation scheme is discarded. As a result, the beam sets created during the import will always be set for sequential delivery even if the original plan indicated an interleaved pattern.

In addition, the delivery order indicated by the beam set order may not match the intended delivery order. As a consequence, no activities that rely on a correct fractionation scheme shall be performed after the import. {119127}



WARNING!

Export after using DICOM import filter. Avoid exporting data that has been modified by DICOM import filters during DICOM import. This will prevent creating different files with the same DICOM UID. {508832}

**WARNING!**

No error indication when using Storage SCP. There is no indication in RayPlan if patient data import using Storage SCP is incomplete due to e.g., errors during the transfer session or failure with writing file to disc. {508833}

3.1.5 Warnings concerning DICOM export

**WARNING!**

Export failure. When exporting data from the system, always verify that the export was successful. If the export is interrupted due to e.g., hardware failure or operation systems errors, delete any exported data and restart the export. {508805}

**WARNING!**

DICOM RT Structure set export. The DICOM export of the RT Structure set will convert all ROIs to contours and any structure parts outside the upper or lower image set slice will not be included.

This applies to ROI geometries with mesh or voxel representation. Such geometries are typically created by using model-based segmentation or by using 3D ROI interaction tools in RayPlan. The DICOM export only handles contours on image slices, which means that the parts that extend outside the first or last slice of the image set will not be included in the export. Thereby they will not be identical after a DICOM export/import roundtrip into RayPlan or an external system. {508804}

**WARNING!**

Treatment parameters shall be transferred from the RayPlan system using DICOM export. Ensure that control points for a treatment plan are exported from the RayPlan system using DICOM export. The user shall not manually transfer these settings. {508803}



WARNING!

DICOM export of Vero plans. Extra care must be taken when DICOM exporting a plan with multiple isocenters to the Vero R&V system. It is necessary to perform the DICOM export twice, once with the ExacTrac Vero checkbox checked and once with the checkbox unchecked. (125706)



WARNING!

Transaction errors when exporting to iDMS. If an error occurs during plan export there might be no indication in RayPlan. The patient and plan state must be verified by the operator in iDMS. (261843)



WARNING!

Handling of DICOM objects with the same SOP Instance UID. In some cases, RayPlan can produce DICOM objects with the same SOP Instance UIDs but with different content. If two objects with the same UIDs are sent to the same target (e.g., a PACS system), the outcome will depend on the implementation of the receiving system. The user needs to manually verify that the correct object is used for the correct task.

(404226)

3.1.6 Warnings concerning dose computation

General dose computation warnings

**WARNING!**

Dose computation region. The dose computation region is confined to the intersection of the dose grid and the region consisting of dose computation ROIs. The dose computation ROIs include the External ROI, Support and Fixation ROIs, as well as Bolus ROIs assigned to external photon and electron beams. No dose will be scored in the region outside the dose computation region.

External beam therapy

For external beam therapy, all material information from image data will be omitted outside the dose computation region. For all modalities except electrons, the volume outside of the dose computation region is treated as vacuum in the radiation transport (no interactions). For electrons, air is used instead of vacuum, with scattering and energy loss in the radiation transport. RayPlan will not be able to compute a correct dose if any part of a beam intersects image data that is not included in the dose computation region. This could occur if the dose computation ROIs do not cover all relevant image data, or if the dose grid does not encompass the relevant volumes of the dose computation ROIs.

Large errors in dose are expected if any part of the beam enters a dose computation ROI surface which is not covered by the dose grid. An error in dose may also be expected at the exit edges of the dose grid if a too small dose grid is used, since scatter from outside the dose grid is not accounted for. There is no warning in RayPlan if the dose grid does not cover the appropriate region at the exit edges.

Brachytherapy [TG43 dose engine]

The TG43 brachytherapy dose computation is a data-driven model based on measurements and simulations in water. The dose computation disregards any material information and treats the full volume as water both inside and outside the dose computation region. This has two implications with respect to the dose computation region:

- Dose on the surface of a dose computation ROI may be incorrect, since an infinite scattering medium is assumed, and the low-density interface is neglected.
- If the dose grid does not cover the entire External ROI (or any other dose computation ROI), the dose will still be correct at the edges of the dose grid, given that all active dwell points are inside the dose grid. In RayPlan, it is not possible to compute dose if there are active dwell points outside of the External ROI. Inside of the External ROI, the dose grid must cover all active dwell points including at least a 3 cm margin to make sure that high dose values close to the sources are accounted for.

(9361)

**WARNING!**

Ensure that the correct ROI has been assigned as the External ROI. Always verify that the External ROI covers all target ROIs and OARs. Dose volume histograms might be computed erroneously if the entire ROI is not included in the External ROI.

(9360)

**WARNING!**

Ensure that the dose grid covers all intended ROIs. Only the part of an ROI covered by the dose grid is included in the DVH and in the dose statistics computation.

(9358)

**WARNING!**

Dose grid resolution affects dose. Both dose output and shape can be significantly affected by dose grid resolution and alignment. Make sure to use an appropriate dose grid considering factors such as e.g., field size, modulation and patient geometry.

(2305)

**WARNING!**

Pixel padding. If pixel padding is present in the region used for dose computation, the calculated dose may be incorrect. Make sure that the pixel padded Hounsfield Units map to the desired density or make sure to add a material override to the pixel padded region.

If the CT-image has excluded material which will be present at treatment and which is inside the radiation scatter region, it is not recommended to use pixel padded values. Instead, add a material override to each material to include them in the dose computation. Failure to do so might lead to errors in the dose computation.

If everything that is important for radiation transport is inside the CT-image, but the External ROI covers image parts with pixel padding values that correspond to high density Hounsfield Units, this could also lead to errors in the dose computation.

(9354)



WARNING!

Material override for multiple structure sets. If material override is defined for an ROI which does not have any geometry defined in the used image set, there will be no warning when computing dose.

[9353]



WARNING!

Use of CT density for non-human materials. The RayPlan dose computation is tuned to be used with CT data for materials normally found within the human body. For non-human materials, using a density override will usually be more accurate than using CT data information. This applies to ROIs of type Support, Fixation and Bolus for beam structures as well as implants within the patient. Ensure that a material override has been assigned to the ROI if the CT density is intended to be overridden. No warning will be given before dose computation if no material has been assigned.

[404666]



WARNING!

Bolus ROIs need to be assigned to beam(s). Bolus ROIs are regarded as beam properties. In order for a bolus ROI to be used for radiation transport and dose computation for a certain beam, it must be explicitly assigned to that beam. If a bolus is to be used for all beams, it must be assigned to all beams individually. A bolus which is not assigned to any beam in a plan is not going to be included in the dose computation at all. [136280]

**WARNING!**

The use of ROIs of type Fixation and Support. ROIs of type Fixation and Support are intended to be used for regions with patient support, fixation or immobilization devices, and should only be used for structures that are mainly outside of the patient outline. Always use other ROI types for material override within the External ROI. A small overlap with the External ROI is acceptable if the Fixation or Support ROI is mainly outside the External ROI. The use of Fixation or Support ROIs that are mainly within the patient outline, can lead to errors in the calculation of the mass density of voxels that are intersected by both the External and the Fixation/Support ROIs. Refer to the *RSL-D-RP-12A-REF, RayPlan 12A Reference Manual* for more details about these effects. [262427]

**WARNING!**

MR planning: Bulk density assignment. RayPlan planning based only on MR images relies on the user specified bulk-density assignment. Note that for certain configurations/regions, a bulk-density assignment using a homogeneous material will produce an unacceptable dosimetric error. [254454]

**WARNING!**

MR planning: Geometric distortion and field-of-view. MR images intended for planning must have negligible geometric distortion. RayPlan does not include any algorithm for distortion correction. The MR image should cover the patient outline. [261538]

**WARNING!**

Contrast enhanced CT. Contrast agents used to enhance CT image sets will affect the HU values, which can lead to differences between planned and delivered dose. The user is advised to either completely avoid using contrast enhanced CT image sets for treatment planning, or ensure that material overrides for the contrast areas are properly assigned.

[344525]

**WARNING!**

Ensure that doses computed with different dose engines are compatible. Combining or comparing doses computed with different dose engines (e.g., in fall-back, co-optimization, background doses, summation of doses) must be handled with care if the dose convention differs between algorithms and the plan is sensitive to dose in high Z materials.

The electron Monte Carlo dose engines report dose to water with radiation transport in medium. The photon collapsed cone dose engine computes dose to water with radiation transport in different density water, a property which is in between dose to water and dose to medium when computed in medium. The photon Monte Carlo dose engine for RayPlan 12A reports dose to medium with radiation transport in medium. When transported in medium, differences between dose to water and dose to medium for photons have been found to be small for tissues other than bone (1-2%), but the difference can become relatively large for bone (10%) or other high Z materials.

The dose convention for imported doses is unknown to RayPlan, and should be handled with care if the plan is sensitive to dose in high Z materials and if the dose is used as background dose or for dose-mimicking.

(409909)

Electron dose computation warnings

**WARNING!**

Maximum allowed statistical uncertainty does not affect already computed clinical Monte Carlo dose. When changing the Maximum allowed statistical uncertainty in Clinic Settings for clinical Monte Carlo electron dose, be aware that already computed doses are not affected. Doses computed prior to the change may therefore be marked as clinical although they have a statistical uncertainty that would not result in clinical dose if they were recomputed.

(9349)

**WARNING!**

Electron dose calculation for small cutout sizes. Limited accuracy in calculated output for small cutout sizes has been reported for the RayPlan electron dose calculation. A difference between measured and computed output of more than 3% has been reported for cutout sizes of 4x4 cm², and more than 5% for cutout sizes of 2x2 cm².

The user needs to be aware of this limitation and thoroughly verify the output of the calculated electron dose for small cutout sizes.

(142165)

Photon dose computation warnings

**WARNING!**

CBCT photon dose calculation. Dose calculation using a CBCT imaging system may be less accurate than using a CT imaging system since there is a limited set of density levels specified for a CBCT compared to what is normally specified for a CT. The accuracy of the dose calculation using CBCT relates to the tuning of the CBCT scale to density, and how well the real density maps against the selected CBCT density. This must be validated by the clinic before using CBCT doses for clinical decisions. Dose calculation on CBCT image data sets is not supported for electrons.

(9356)

**WARNING!**

Assignment of CBCT density table. For direct usage of the raw CBCT information in dose computation, RayPlan uses an image-specific CBCT density table. Since there is a limited set of density levels specified for a CBCT compared to what is normally specified for a CT, dose computation on CBCT images may be less accurate than using CT images or converted CBCT images. The accuracy of the dose computation using CBCT with an assigned density table relates to the tuning of this table, and how well the real density in the patient maps to the selected densities in the table.

Always review the density table before it is used in dose computation. The review can be performed through spot check of selected slices in the Create Density Table for CBCT dialog where the effect of the density table is visualized.

(9355)

**WARNING!**

Maximum allowed statistical uncertainty does not affect clinical status of already computed Monte Carlo dose. When changing the Maximum allowed statistical uncertainty in Clinic Settings for clinical Monte Carlo photon dose, be aware that already computed doses are not affected. Doses computed prior to the change may therefore be marked as clinical although they have a statistical uncertainty that would not result in clinical dose if they were recomputed.

(399)

**WARNING!**

Asymmetry in CyberKnife Y-profiles for MLC collimated fields not accounted for in beam modeling. For the largest MLC collimated fields, the Y-profiles of the CyberKnife LINAC show an intrinsic asymmetry. This is not accounted for in beam modeling, and differences between delivered and computed doses may appear for fields collimated directly by one of the fixed Y-jaws (the side protection plates of the MLC), or by a few closed leaf pairs next to one of the Y-jaws.

The user should be aware of this limitation and be extra careful in examining this behavior in the commissioning of RayPlan and in the subsequent patient-specific QA.

(344951)

Brachytherapy dose computation warnings

**WARNING!**

Validity of TG43 dose calculation. The TG43 dose calculation is based on a number of assumptions: (1) all tissue around the sources are water-equivalent, (2) each source must be surrounded by a sufficiently large patient volume to keep the validity of the consensus data set, and (3) any shielding effects can be neglected. Situations when these assumed conditions are not met include: plans where the source is close to air cavities or metal implants, setups including applicator shielding and sources placed close to the skin.

The user must be aware of these assumptions and how they will affect the dose computation.

(283360)

**WARNING!**

Correctness of TG43 parameters. The accuracy of the brachytherapy TG43 dose computation is strongly dependent on the correctness of the TG43 parameters used. If available for the current source, it is strongly recommended to use published consensus data from the HEBD report (Perez-Calatayud et al., 2012) or similar reports. The resolution of the radial dose function and the anisotropy function should follow the recommendations given in the TG43u1 report (Rivard et al. 2004) and in the HEBD report. It is the responsibility of the user to verify that the TG43 parameters have been entered correctly, regardless of whether it is the user or the manufacturer that has entered the data. The user must also check the accuracy of the dose calculation algorithm using the entered parameters.

(283358)

**WARNING!**

Transit doses in brachytherapy. Doses delivered in between dwell positions, as well as entrance and exit doses from and to the afterloader, are not accounted for in the dose computation. These transit doses are dependent on the source strength and the actual movement (speed and acceleration) of the source within the HDR brachytherapy channels. The transit doses can reach clinically significant levels in some cases, especially for high source strengths, slow source movement and when the number of HDR brachytherapy channels is large, resulting in the source spending a significant portion of the time in transit. The user should be aware of this limitation and assess in which cases transit doses might become an issue for each afterloader and source.

(331758)

**WARNING!**

HDR brachytherapy delivery in magnetic fields. If the HDR brachytherapy treatment is performed in a magnetic field (e.g. delivery during MRI), there might be large discrepancies between delivered dose and dose computed using the TG43 formalism. The derivation of published TG43 parameters does not include magnetic fields and any effect on the dose distribution will thus be disregarded in the dose computation. The user must be aware of this limitation if the treatment is to be delivered in a magnetic field. Special care should be taken for ^{60}Co sources and for magnetic field strengths larger than 1.5 T.

(332358)

3.1.7 Warnings concerning patient modeling



WARNING!

Automatic ROI generation and modification. Always verify the outcome of automatic ROI generation and modification. Special attention should be given to choosing the appropriate organ model for the patient based on characteristic model properties such as body region, patient position, and image modality. This applies to all automatic segmentation methods including model-based segmentation and atlas-based segmentation.

Note that no automatic organ segmentation may be used to identify lesions in RayPlan.

(9662)



WARNING!

Automatic image registration. Always verify the outcome of automatic image registration. (360374)



WARNING!

Image set slice spacing and extrapolation of contours. In RayPlan, the 3D reconstruction of an ROI from contours assumes that the first and last contours extend half a slice distance. The first and last contours of an ROI are therefore extrapolated half a slice distance from the outermost drawn contours. Note that there is no limit for this extrapolation, it is always half a slice distance. For typical image sets with a slice distance of about 2-3 mm this means that RayPlan extrapolates 1-1.5 mm, but in an image set with wide slice spacing, this extrapolation may lead to unexpected behavior. It is therefore highly recommended to always use planning CTs reconstructed with a slice spacing less than or equal to 3 mm. (125440)

**WARNING!**

Missing intermediate ROI contours. If there are missing intermediate ROI contours, the gap is NOT filled in automatically.

If there are image slices with missing contours between the outermost contours of the ROI geometry, no automatic interpolation is performed between the contours. This applies to imported contours as well as contours generated in RayPlan. [360375]

**WARNING!**

ROI geometry extending outside the image set. When performing a contour operation (e.g., manual drawing, simplify contours etc.) on an ROI that extends outside the top or bottom of the image set, the ROI will be cut at the top and bottom slices of the image set. [240137]

**WARNING!**

Create common material with new elemental composition. It is possible to define a material which does not reflect a physically reasonable material with respect to the combination of mass density and elemental composition. Be careful with the order of atomic numbers and weights to make sure that both have the same order. The dose engines in RayPlan are optimized for materials similar to those found in the human body. Using materials outside that domain may decrease the dose accuracy. [274572]

3.1.8 Warnings concerning treatment planning

**WARNING!**

Collision avoidance: Always verify patient position, gantry angles and couch angles (ring angles instead of couch angles for the Vero machine). The patient/machine setup must be manually verified for all beams to avoid collisions causing patient injury or equipment damage. The Room view shall not be used to verify that no collisions will occur with current patient/machine set up. For TomoTherapy treatments, see also warning 254787.

(3310)

**WARNING!**

Select correct treatment position. Make sure that the correct treatment position (head first/feet first) is selected for the patient when creating a treatment plan. The selected treatment position will affect how beams are oriented relative to the patient. Incorrect specification may lead to mistreatment of the patient.

Note that a treatment position different from the patient position in the CT data (patient scanning position) can be selected when a plan is created. Only use this option if the patient is to be treated in a different position than he/she was positioned in during scanning. (508900)

**WARNING!**

Collimator angle for VMAT, Conformal Arc and Static Arc. Collimator angles 0, 90, 180 and 270 degrees should if possible be avoided for arc beams as these may lead to accumulated dose leakage. The collimator angles should preferably be shifted at least 10 degrees from the above values. The accumulated dose leakage due to interleaf transmission is not reproduced by the clinical dose computation. Be aware of this when making clinical decisions. Closed leaf pairs are likely to be positioned in the middle of the target projection which may accumulate the leakage to the center of the target at these collimator angles.

(3305)

**WARNING!**

Computing dose for small structures. When using small structures it is important to be aware of that they may be significantly affected by discretization effects. It is therefore important to choose dose grid resolution based on the smallest structures that need to be reconstructed. When structures are reconstructed for visualization in patient views, a structure-specific high-resolution grid is used in order to represent the structure accurately. However, for plan optimization, dose computation and dose statistics, the structures are reconstructed on the dose grid. If the dose grid voxels are too large, the reconstruction may represent the structures inaccurately. Furthermore, there will be a discrepancy between the visualized structures and what is actually used for dose computations. It is therefore highly recommended to use a dose grid resolution such that the size of one dose grid voxel does not exceed half the size of the smallest structure to be reconstructed.

(254767)

**WARNING!**

Material visualization. The material view displays the combined voxel densities from CT values and material overrides. Any material override ROIs inside the External ROI and ROIs of type Support and Fixation are included in this density computation. Note that ROIs of type Bolus are not included in the view.

Apart from Bolus ROIs, the displayed density values are the voxel densities used for dose computation. The user is advised to carefully review this density distribution to ensure that the input to the dose computation is correct.

The same precautions apply when Stopping Power Ratios (SPR) are used as input for proton and light ion dose computation.

2638

**WARNING!**

Pitch and roll of couch affect patient geometry. When planning or performing imaging with a pitch or roll of the couch, be aware that there is no validation in RayPlan that the patient rotation in the image matches the patient rotation in the treatment plan.

(68044)

3.1.9 Warnings concerning TomoHelical and TomoDirect planning

**WARNING!**

Collision avoidance for TomoHelical and TomoDirect. After isocenter adjustments, always make sure that the patient will fit comfortably on the couch in the gantry bore. The 2D and 3D views include machine specific FOV and Bore visualization that can be used to verify that no collisions will occur. Do not use the Room view to verify collision avoidance. {25478?}



WARNING!

TomoDirect treatment through the couch. The TomoTherapy couch consist of a fixed lower pallet and a movable upper pallet. The upper pallet position during delivery can be different from the planning position due to lateral patient setup adjustments. This can influence dose for beams entering through or close to the edge of the upper pallet. Daily gantry roll corrections can also change the path of the beam through the couch. Avoid creating TomoDirect plans with a large fraction of the dose from beams entering through or close to the edge of the upper pallet.

(5062)



WARNING!

Single Patient DB per iDMS. An iDMS shall only receive data from one Patient DB in order to avoid consistency errors. A patient lock in Patient DB ensures that the same patient is not exported to iDMS simultaneously from two RayPlan instances.

(261846)



WARNING!

Motion synchronization for TomoHelical plans. When motion synchronization is used for a TomoHelical plan, three imaging angles (0, 90, 270 degrees) are created as a starting point. The user needs to manually edit the angles, evaluate them and make sure that they are appropriate for imaging of the selected targets to track.

At approval or export, the angles are validated to ensure that they do not violate some constraints. For example, all angles need to be separated by at least 30 degrees. However, note that there is no validation that the angles are well-suited to be used for target tracking.

(143545)

**WARNING!****Do not use 'Fiducial' in ROI/POI names when using TomoHelical with Synchrony.**

For TomoHelical plans using real-time tracking and motion management support, 'Fiducial' should not be used in the ROI/POI name. The Treatment delivery system identifies which fiducials to track by this naming convention. Using the name 'Fiducial' in ROI/POI names might cause problems on the delivery side with incorrect ROI/POIs to be set as tracked as well as duplicate ROI/POI names. Incorrect fiducial usage will result in failure to deliver the plan on the machine.

(282912)

3.1.10 Warnings concerning CyberKnife treatment planning

**WARNING!****A created 1-view margin ROI has no dependency on the selected tracking technique or source ROI.**

After a 1-view margin ROI is created, it has no dependency on the motion synchronization technique of the beam set, nor on the source ROI. If the motion synchronization is changed, or the source ROI is updated, regenerate the margin ROI.

(341543)

3.1.11 Warnings concerning brachytherapy treatment planning

**WARNING!**

Validation of application setup properties prior to clinical use. It is the user's responsibility to validate that the parameters defined for an application setup correctly represent the corresponding applicator before clinical use. In particular, the correct position of the dwell points must be verified.

(283879)

**WARNING!**

Afterloader limits. The limits specified for an afterloader in RayPlan Physics must be specified within the limits of the actual afterloader. In particular, the dwell time limits specified in RayPlan Physics must correspond to the reference air kerma rate times of the current source. The limits specified in RayPlan Physics should be set so that the actual limits of the afterloader are fulfilled also after the dwell times have been rescaled to compensate for the difference between reference air kerma rate and the actual air kerma rate at treatment delivery.

(283881)

**WARNING!**

Number of sources. For a brachytherapy beam set, it is only possible to have one source defined.

(283883)

**WARNING!**

Brachytherapy dwell point positioning. The correctness of the in-patient dose distribution strongly depends on the accuracy in positioning of the channels and dwell points. It is the responsibility of the user to verify that the channels are correctly positioned for each patient and that the representation of dwell points inside the channels is correct.

(283361)

**WARNING!**

Reported dose for brachytherapy. All dose values in RayPlan are reported as absorbed physical dose for brachytherapy. It is recommended to perform clinical evaluation of brachytherapy treatment plans using the biologically weighted EQD2 dose in addition to the absorbed dose. There is currently no direct display of EQD2 doses in the graphical user interface and it is the responsibility of the user to convert reported dose values to EQD2 doses.

(284048)

**WARNING!****Summation of brachytherapy and external beam radiotherapy doses.**

Brachytherapy treatment plans normally hold significantly higher fraction doses than external beam radiotherapy plans. When there are large differences in fraction dose prescriptions, doses should not be summed directly without considering radiobiological effects (using concepts such as BED and EQD2).

(283362)

**WARNING!**

Limitations of the EQD2 formalism. The equivalent dose in 2-Gy fractions (EQD2) implemented in RayPlan is based on the standard linear-quadratic (LQ) model, which has the following implications that the user should be aware of:

- The model assumes complete repair between fractions and disregards repopulation of tumor cells. Therefore, in cases where complete repair between fractions is not achieved, the biological effects will not be adequately modeled. Furthermore, when repopulation of tumor cells becomes important, for example due to interruptions in the treatment or for rapidly proliferating tumors, the EQD2 dose will not be fully correct.
- The uncertainties in the LQ model become larger for low prescribed doses (below 1 Gy) and high prescribed doses (8 Gy) per fraction. Consequently, the EQD2 doses are less reliable for such dose levels.
- The EQD2 doses are strongly dependent on the α/β -values used in the evaluation. The user is advised to consider a range of α/β -values in the evaluation and investigate worst-case scenarios for EQD2, especially when normal tissue tolerance may be compromised.
- EQD2 doses do not depend linearly on the physical dose, which means that cold and hot spots are enhanced when translating physical dose to EQD2 and gradients in the EQD2 distribution are higher than in the physical dose distribution. It is therefore advised to not evaluate EQD2 in a single point only but use multi-point evaluations to account for differences throughout the volume. Furthermore, when the EQD2 evaluation is based on volumes in the DVH, it is advised to use more than one clinical goal. For example, a clinical goal on EQD2(D90) could be complemented with clinical goals for other accumulated volumes than 90% of the total ROI volume. Volume effects can be analyzed further in the full EQD2 distribution, as obtained from the EQD2 computation in Plan Evaluation.

(406776)

**WARNING!**

Interpretation of EQD2 distributions. An EQD2 distribution differs from the corresponding physical dose distribution in several aspects and special care must be taken when interpreting EQD2 dose distributions:

- Evaluation criteria for physical dose cannot be used directly when evaluating EQD2 distributions. The physical dose criteria must always first be converted to the EQD2 domain. This is essential also for treatments prescribed at 2 Gy per fraction to the tumor: even if the prescribed dose in the tumor will be 2 Gy per fraction both in physical dose and in EQD2, cold and hot spots inside the tumor will be enhanced in the EQD2 domain. More importantly, normal tissue tolerances can differ significantly between the physical dose and the EQD2 distribution also for 2 Gy-fractionated treatments.
- For an EQD2 distribution computed in Plan Evaluation, adjacent or overlapping ROIs can be assigned with different α/β -values and the EQD2 distribution will be discontinuous across boundaries between ROIs with different α/β -values. For overlapping ROIs, a priority between the ROIs in the EQD2 computation determines which α/β -value to be used in a voxel belonging to more than one ROI. The result is that the α/β -value specified for an ROI may only be used in part of the ROI.
- To ensure that a specific α/β -value is used to evaluate a clinical goal in the EQD2 domain, it is recommended to first extract the clinical goal for the physical dose and then convert it to EQD2 with the α/β -value of choice, rather than extracting the clinical goal directly from the EQD2 distribution. Reporting of EQD2 metrics is common in brachytherapy, and RayPlan supports EQD2 clinical goals in the brachytherapy module, which automatically performs the recommended conversion.

(408774)

3.1.12 Warnings concerning dose evaluation

**WARNING!**

Interpolated dose values are shown in the patient views. Interpolated dose values are shown in the patient views by default. Ensure that an appropriate dose grid resolution for the specific treatment planning situation is used.

(3236)

**WARNING!**

Display of total dose. It is always the total dose for all planned fractions that is displayed in the patient views, the DVH graph, the dose statistics and in the clinical goals list.

The exception is the QA module, where the dose is displayed for one fraction.

[3233]

**WARNING!**

System checks at approval. Be aware that the following checks before approval are only performed for planning doses:

- Beam entry validation.
- A Bolus ROI geometry exists.
- A Support ROI geometry exists.
- A Fixation ROI geometry exists.
- The Dose grid resolution is smaller than 5 mm in all directions.

For evaluation doses, the user is responsible for performing these checks.

Note that having a planning dose grid which encloses the External ROI, support ROIs, fixation ROIs and bolus ROIs does not guarantee that all relevant regions are included for dose computation on additional datasets. [508962]

**WARNING!**

Approximate dose is only intended for intermediate treatment planning steps.

Approximate dose has lower accuracy compared to the dose displayed as "Clinical" and it must not be used for clinical decisions. A plan with approximate dose cannot be approved or exported.

[9405]

3.1.13 Warnings concerning beam commissioning

General beam commissioning



WARNING!

Beam model quality depends on beam data. The quality of the beam model depends critically on the quality and scope of the beam data, for example, dose curves, output and wedge factors, absolute calibration, phantom size and collimation settings which influence the curve field setup. The entered measurement conditions must match the measurement technique. The sizes of the measured fields should cover the field sizes of the future applications of the beam model.

All input data, such as measured curves and output factors, must be coherent and correspond to the delivery system which is to be commissioned. Otherwise the generated beam model will not be able to calculate a correct dose.

For more information, refer to the *RSL-D-RP-12A-BCDS, RayPlan 12A Beam Commissioning Data Specification*.

[3188]



WARNING!

Machine constraints. If the machine constraints defined in RayPlan Physics do not reflect the treatment machine and R&V-system behavior, the plans can either be stopped at delivery or adjusted outside RayPlan giving a situation where the delivered dose differs from the approved dose. When creating a machine model from a template, ensure that all machine constraint parameters are adapted to your specific treatment machine.

Even if RayPlan adheres to all machine constraints specified in RayPlan Physics, there is no guarantee that all plans will be possible to deliver. Ensure that plans are not modified outside RayPlan in a way that significantly affects dose without proper evaluation.

[3185]

**WARNING!**

Beam model parameters. The accuracy of the dose computation depends critically on the beam model parameters established during beam commissioning. Before a machine is commissioned, all beam model parameters must be carefully reviewed by a person with proper training.

[9377]

**WARNING!**

Always review curves after import. Always review curves after import to ensure consistency with the measurement situation. The beam model quality depends critically on correctness of the imported data.

[9373]

C-arm, TomoTherapy and CyberKnife LINAC beam commissioning

**WARNING!**

Modulated dynamic arc machines require information about collimator motion, gantry motion and dose rates. Deviation between the selected values and LINAC/R&V-system behavior may result in differences between delivered dose and dose approved in RayPlan.

[3183]

**WARNING!**

Siemens virtual wedge. The Siemens virtual wedge parameters mean linear attenuation and calibration shall be adjusted from the default values to the proper values for your LINAC. Failure to do so may lead to error in the computed clinical dose.

[3180]

**WARNING!**

Dose curve wedge orientation. The wedge orientation for wedged curves is determined from the curve at import. All wedge angles must have been measured with the same orientation. If all curves do not have the same wedge orientation, then no curves will be imported. For curves where the orientation cannot be determined, it is assumed to be identical to other curves imported at the same time.

(9371)

**WARNING!**

Collimator calibration. The collimator calibrations (offset, gain and curvature) are used to shift the collimator positions from the plan positions (shown in the Beam's Eye View, in beam lists, in reports, exported in DICOM etc.) to an effective position used in dose computation. For dose curves this only shifts the penumbra, but for a VMAT, SMLC or DMLC field with many segments adding up, this can change the overall dose level. Ensure that the collimator shift in the beam model is really intended. Be extra careful with gain and curvature shifts which increase with increasing distances from the origin. Results from the auto-modeling collimator calibration step must be reviewed before clinical use.

(9368)

**WARNING!**

Beam profile correction and off-axis softening at large field radii. The photon beam model parameters *Beam profile correction* and *Off-axis softening* cannot be evaluated at large radii in the Beam commissioning module without having imported diagonal profiles which extend to the corners of the field. Special care must be taken when using auto-modeling for the *Beam profile correction* and *Off-axis softening* parameters if there are only x- and y-profile curves imported into the Beam commissioning module. Be aware that manual adjustments of these parameters at large radii will be necessary after using auto-modeling without diagonal curves. The Beam 3D modeling module can be used to check the calculated dose of the entire field, including corners, before commissioning a machine (not available for CyberKnife LINACs).

(3438)

**WARNING!**

Non-standard fluence mode. When modelling a photon beam quality with non-standard fluence mode (FFF/SRS), it is essential to select the correct fluence mode when adding the beam quality. If the fluence mode is not set correctly, plans using the beam quality may be misinterpreted by the LINAC, leading to incorrect delivered dose.

If standard fluence mode is used for the beam quality, RT Plans will set Fluence mode to "STANDARD" and the Fluence mode ID is not exported.

If non-standard fluence mode is selected, RT Plans will set Fluence mode to "NON_STANDARD" and the Fluence mode ID to the selected fluence mode (FFF/SRS).
(9365)

**WARNING!**

Dose computation photon beam energy and nominal photon beam energy. The RayPlan photon dose computation internally uses a photon energy definition according to BJR #11 (British Journal of Radiology supplement number 11). It is possible to specify a nominal photon beam energy which is different from the dose computation energy, for example to use a photon energy definition according to BJR #17.

The nominal energy will be displayed in the RayPlan user interface, used in reports and as DICOM Nominal Beam Energy in both DICOM import and export.

The dose computation energy will be used for photon dose computation, including to get the correct golden segmented treatment table (GSTT) parameters for dose computation with Varian Enhanced Dynamic wedge. It is therefore crucial to set a correct dose computation energy regardless of the selected energy definition.
(4889)

**WARNING!**

TomoTherapy leaf latency offsets affect both dose output and shape. Leaf latency offsets are imported from iDMS, and can also be edited in RayPlan Physics. Changes to leaf latency offsets may have different effect for different jaw field sizes, projection times and leaf opening times. Ensure that dose accuracy is validated for all jaw openings and over the full range of clinically relevant projection times and leaf opening times before using the model clinically.
(1404)

**WARNING!**

TomoTherapy dose computation accuracy for short leaf open times and short leaf close times. For TomoHelical and TomoDirect plans with a large number of short leaf open times or a large number of short leaf close times, the delivered dose may differ significantly from the computed dose. The reason is that for fast leaf movements, the treatment machine will not open/close the leaves in accordance with the model used in the dose computation.

To avoid short leaf open times and short leaf close times when creating plans in RayPlan, use the beam model parameters *Minimum leaf open time* and *Minimum leaf close time*. The issue will occur with certain machine-specific leaf open/close time characteristics, but around 50 ms can normally be an appropriate value for both *Minimum leaf open time* and *Minimum leaf close time*.

To find the appropriate values for *Minimum leaf open time* and *Minimum leaf close time* for each TomoTherapy treatment unit, leaf latency data can be measured as described in *Westerly DC, Soisson E, Chen Q, Woch K, Schubert L, Olivera G and Mackie TR, Treatment planning to improve delivery accuracy and patient throughput in helical tomotherapy, Int J Radiat Oncol Biol Phys. 2009;74(4):1290–1297.*

(7551)

3.1.14 Warnings concerning QA

**WARNING!**

Use the exported treatment plan for plan verification. Using the treatment plan for QA measurements provides an opportunity to detect errors in data transfer or dose calculation. It is recommended to only use the QA plan for computing QA dose and to perform QA measurements using the treatment plan. If it, for some reason, is not possible to use the treatment plan for performing QA measurements, make sure that the QA plan setup is as close as possible to the treatment plan setup and that the effects of the differences are understood. [9438]

**WARNING!**

Collapse of gantry angles for arc beam QA. Collapse of gantry angles to a single angle for arc beams (VMAT and Conformal Arc) in the QA Preparation module is intended for QA with a detector mounted perpendicular to the treatment beam and rotating with the gantry. The dose computed in the QA Preparation module can be used, but the QA delivery shall be performed with a rotating gantry to detect any delivery problems related to gantry rotation. For details about dose computation for arc beams and collapsed arc beams, refer to the *RSL-D-RP-12A-REF, RayPlan 12A Reference Manual*.

(2380)

3.1.15 Warnings concerning RayPlan Storage Tool**WARNING!**

Verify database consistency before upgrade. In the RayPlan Storage Tool it is possible to create a new database system based on an existing system. Before creating a new system based on an existing system, make sure to run the ConsistencyAnalyzer tool. {231801}

**WARNING!**

RayPlan Storage Tool. When RayPlan Storage Tool opens a previous version of ResourceDB, the ResourceDB will be upgraded and cannot be used with earlier versions. {261396}

**WARNING!**

Transfer mode for secondary databases. If a patient database is used as a secondary database in more than one system, the transfer mode is the same.

(466425)

3.2 IMPORT OF PATIENT DATA

All patient data is imported using DICOM. The patient data import procedure is described in the User Manual, *RSL-D-RP-12A-USM, RayPlan 12A User Manual*, and the DICOM Conformance Statement, *RSL-D-RP-12A-DCS, RayPlan 12A DICOM Conformance Statement*.

3.3 INPUT DATA

All user input data is validated at the time of input. Incorrect values or text are rejected, correct limits or format is displayed and the user is prompted for new input.

3.4 DISPLAY FORMAT

In RayPlan, date and time are displayed in format "dd MMM YYYY, hh:mm:ss (hr:min:sec)", for example, "14 Jan 1975, 08:20:42 (hr:min:sec)".

4 INSTALLATION INSTRUCTIONS

This chapter describes the processes and tests related to the installation of the RayPlan 12A system.

In this chapter

This chapter contains the following sections:

4.1	Installation manual	p. 64
4.2	System environment acceptance test	p. 64
4.3	Hardware diagnostics checks	p. 64
4.4	Data communication environment	p. 64

4.1 INSTALLATION MANUAL

For installation manual, refer to *RSL-D-RP-12A-CIRSI, RayPlan 12A Customer Instruction for RayPlan Installation*.

4.2 SYSTEM ENVIRONMENT ACCEPTANCE TEST

The system environment acceptance test must be run for each installation or change in hardware or software platform hosting the application (e.g., operating system update) to verify application installation and performance. The test is defined by *RSL-D-RP-12A-SEAT, RayPlan 12A System Environment Acceptance Test Protocol*.

4.3 HARDWARE DIAGNOSTICS CHECKS

To prevent RayPlan or RayPlan Physics from running in a faulty hardware environment, a self-test is run at the start of each action requiring GPU computation. Depending on which action that is requested (e.g., collapsed cone photon dose) a specific test is run and the result is compared to a predefined list of results from approved environments. A successful test is valid until RayPlan or RayPlan Physics is closed, and the test will not be run again for subsequent actions protected by the same self-test.

If the test fails, the user is notified and no GPU computations will be possible using an action protected by the failing self-test. Other GPU computations where the self-test succeeds can still be run.

The test is run for all GPUs selected to be used for accelerated computations. Nevertheless, it is the responsibility of the user to absolutely ensure that the selected cards together with OS version, driver version and other environment details are listed as valid combinations in the *RSL-D-RP-12A-SEG, RayPlan 12A System Environment Guidelines*. Additionally, before clinical use, the operation of GPU computations must be verified by a qualified physicist using the *RSL-D-RP-12A-SEAT, RayPlan 12A System Environment Acceptance Test Protocol*.

4.4 DATA COMMUNICATION ENVIRONMENT

The RayPlan 12A system communicates with other systems using DICOM. For detailed information, see *RSL-D-RP-12A-DCS, RayPlan 12A DICOM Conformance Statement*. It is the responsibility of the user clinic to establish that the connectivity between RayPlan and the systems it imports data from works according to expectations and that exported data is correctly handled by the receiving systems.

5 DISPLAY OF COORDINATES, MOVEMENTS AND SCALES

RayPlan 12A uses the IEC 61217³ standard for display of coordinates, movements and scales during treatment planning, with a few exceptions. The gantry, collimator and couch angles, as well as the field coordinate system may be user configured, per C-arm LINAC, to be non-IEC. Also, the CyberKnife treatment machine is partly described with a non-IEC coordinate system. For more details on the user-defined exceptions, as well as the CyberKnife exception, see *section 5.3 The treatment machine coordinate system on page 68*.

Note: *Patient positions Head First Supine (HFS), Head First Prone (HFP), Feet First Supine (FFS), Feet First Prone (FFP), Head First Decubitus Left (HFDL), Head First Decubitus Right (HFDR), Feet First Decubitus Left (FFDL), and Feet First Decubitus Right (FFDR) are supported by RayPlan 12A. Not all patient positions are, however, supported for all different treatment techniques.*

In this chapter

This chapter contains the following sections:

5.1	The patient coordinate system	p. 66
5.2	Patient coordinate system in the DICOM export	p. 67
5.3	The treatment machine coordinate system	p. 68
5.4	The jaw and MLC labeling standard	p. 83

³ IEC 61217:2011 Radiotherapy equipment – Coordinates, movements and scales.

5.1 THE PATIENT COORDINATE SYSTEM

The patient coordinate system is oriented with the positive x-axis towards the patient's left arm, the positive y-axis towards the patient head and the positive z-axis in the anterior direction. The coordinate system follows the patient orientation: head first or feet first, supine or prone, decubitus right or decubitus left. In the hierarchy of IEC 61217 coordinate systems, the patient coordinate system has the table top coordinate system as its mother system.

The RayPlan 12A dose and the dose difference distributions are all visualized in the patient coordinate system. In general, in RayPlan 12A the patient coordinates are reported as **Right-Left, R-L** (right-left = x -/+), **Inf-Sup, I-S** (inferior-superior = y -/+) and **Post-Ant, P-A** (posterior-anterior = z -/+).

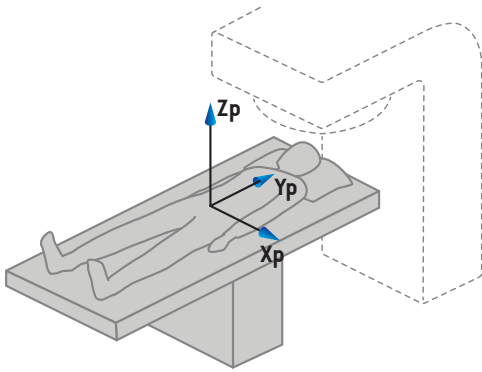

A) Head First Supine

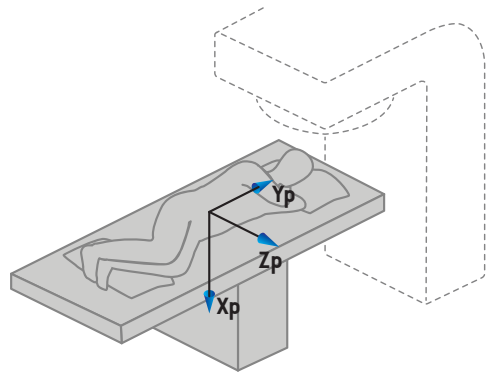

B) Head First Decubitus Left

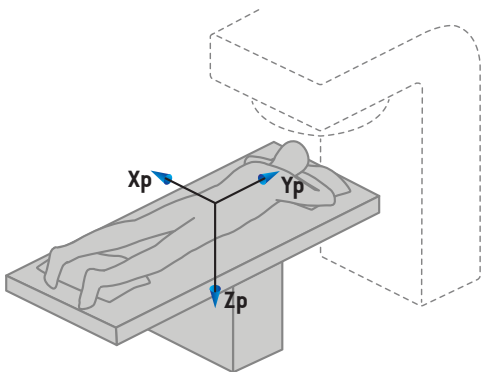

C) Head First Prone

Figure 2. The patient coordinate system. Some examples of supported positions are illustrated: A) Head First Supine (HFS), B) Head First Decubitus Left (HFDL), and C) Head First Prone (HFP).

5.2 PATIENT COORDINATE SYSTEM IN THE DICOM EXPORT

Patient coordinates in DICOM exported data sets follow the DICOM standard, with the positive x-axis towards the patient's left arm, the positive z-axis towards the patient head and the positive y-axis in the posterior direction. The coordinate system follows the patient orientation: head first or feet first, supine or prone, decubitus right or decubitus left.

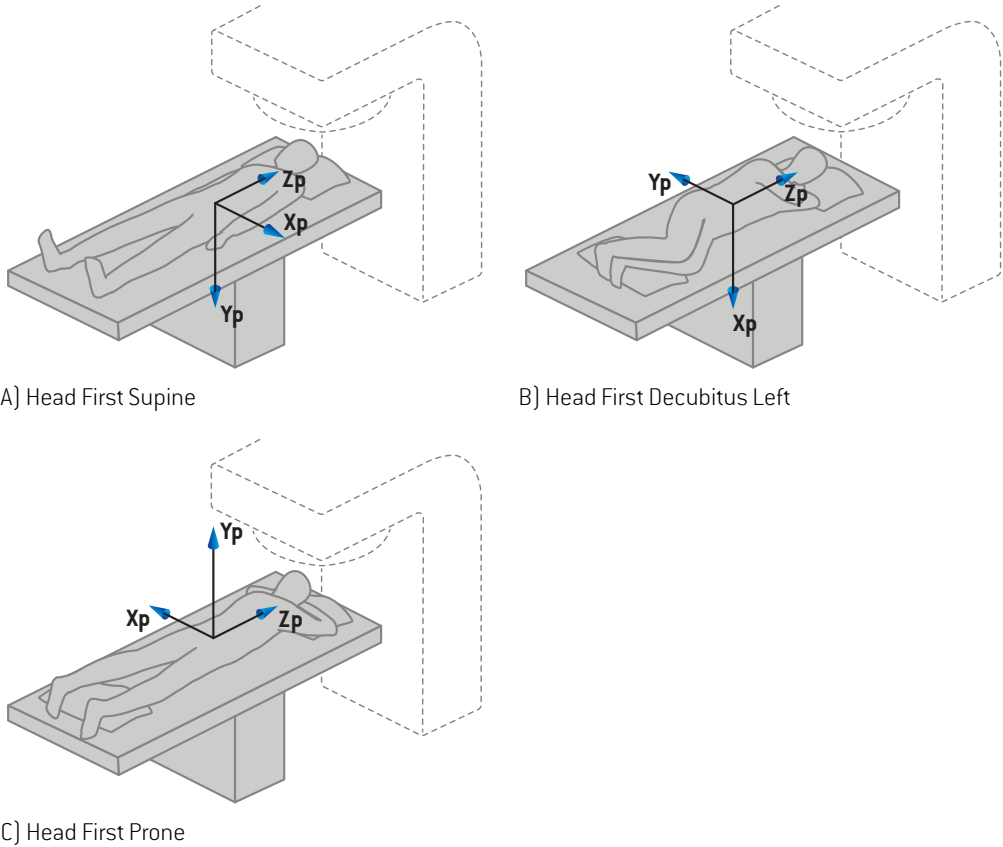

Figure 3. The patient coordinate system in the DICOM export follows the DICOM standard. Some examples of supported positions are illustrated: A) Head First Supine (HFS), B) Head First Decubitus Left (HFDL) and C) Head First Prone (HFP).

5.3 THE TREATMENT MACHINE COORDINATE SYSTEM

RayPlan 12A uses the IEC 61217 standard for display of LINAC coordinates, movements and scales during treatment planning, with the exception of gantry, collimator and couch angles as well as the field coordinate systems, which may be configured, per C-arm LINAC, to be non-IEC. There are also two options for jaw labeling. Setup imagers may also be described using non-IEC rotations, see *section 5.3.10 Setup imager coordinate systems on page 81*. The CyberKnife radiation head movements cannot be described using the IEC 61217, see *section 5.3.8 The CyberKnife radiation source coordinate system on page 77*.

5.3.1 The machine coordinate systems overview

The machine coordinate systems in IEC 61217 are a set of coordinate systems, each defined in relation to its mother coordinate system, starting with a fixed coordinate system which has the origin at the isocenter, the positive x direction to the right for an observer facing the gantry, the positive y-axis from the isocenter towards the gantry along the axis of gantry rotation and the positive z-axis directed upwards from the isocenter.

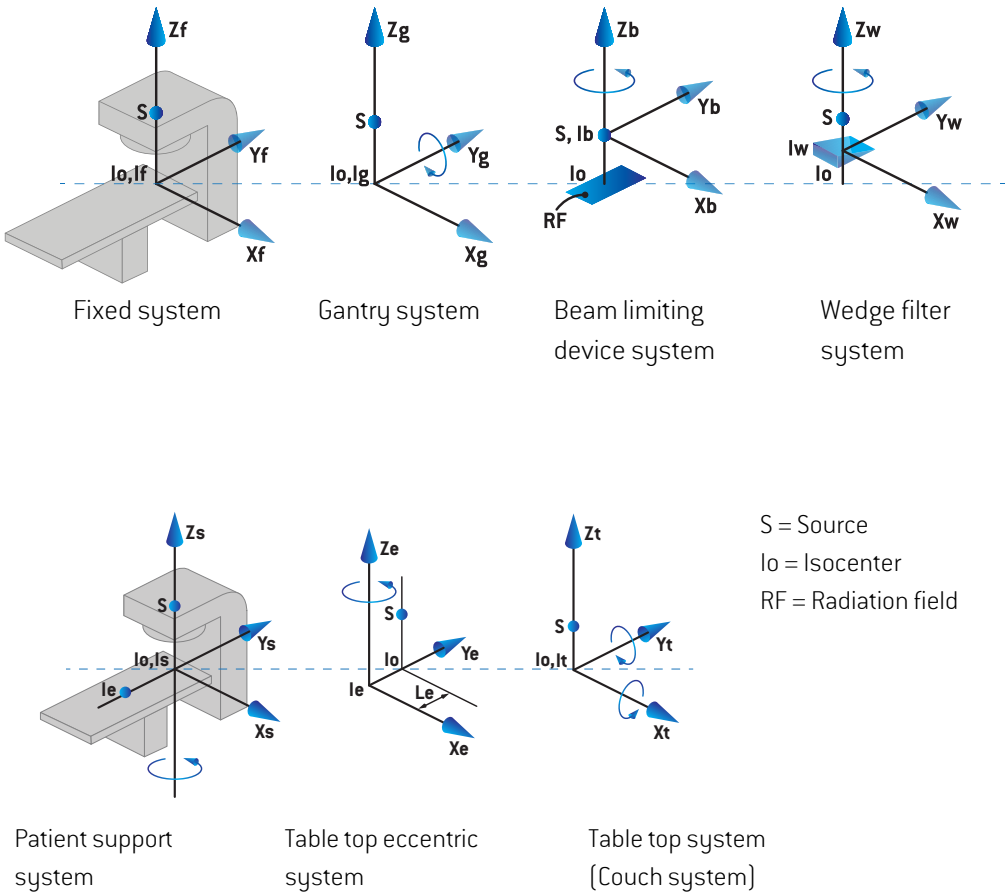

Figure 4. The machine coordinate systems according to the IEC 61217 standard.

If the machine is commissioned to replace the couch rotation by the ring rotation (e.g., the Vero machine), the rotation around the Zs axis in the patient support coordinate system is replaced by a rotation in the opposite direction around the Zg axis in the gantry coordinate system. The relationship between the patient and the gantry systems is thus maintained.

5.3.2 The gantry coordinate system

The gantry coordinate system rotates with the gantry. The gantry coordinate system has the fixed coordinate system as its mother system.

- For **IEC standard**, it is defined to coincide with the fixed coordinate system when the gantry angle is zero. The gantry angle increases gradually for clockwise rotation as viewed by an observer facing the gantry.

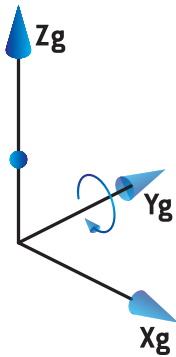

- For **Non-IEC gantry scale (Varian Standard)**, the gantry angle is 180 degrees when the beam enters from above. The gantry angle increases gradually for counter clockwise rotation as viewed by an observer facing the gantry.

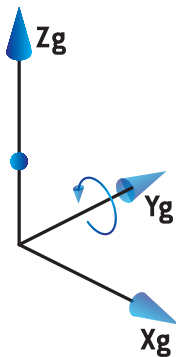

Note: If a LINAC is configured to use gantry angle as IEC 61217, the angle unit is given as [deg].

Note: If a LINAC is configured to use gantry angle as Non-IEC ("Varian Standard"), the angle unit is given as [deg Non-IEC].

5.3.3 The beam limiting device coordinate system

The beam limiting device coordinate system is fixed in the gantry beam limiting device. The beam limiting device coordinate system has the gantry coordinate system as its mother system.

There are three settings in RayPlan Physics that affect the behavior of angles, positions and names in this coordinate system; the **Gantry and collimator coordinate system definitions**, the **Field coordinate system definitions** and the **Jaw labeling standard**. If all three settings are set to "IEC 61217", the definitions are consistent with those in the IEC 61217 standard.

The Gantry and collimator coordinate system definitions setting

The **Gantry and collimator coordinate system definitions** setting in RayPlan Physics controls the reporting of the beam limiting device rotation angle:

- For **IEC standard**, the axes coincide with the gantry system when the collimator angle is zero. The collimator angle is defined to be positive for counterclockwise rotation in the Beam's eye view, i.e. when viewed from the source. For this coordinate system, the collimator angle is usually 180 degrees when the tray opening is facing the gantry for Varian machines.
- The **Non-IEC (Varian Standard)** collimator coordinate system is rotated 180 degrees compared to the IEC standard and the collimator angle is defined to be positive for a clockwise rotation in the Beam's eye view, i.e. when viewed from the source. For this coordinate system, the collimator angle is usually zero degrees when the tray opening is facing the gantry for Varian machines.

Note: *If a LINAC is configured to use a collimator angle as IEC 61217, the angle unit is given as [deg].*

Note: *If a LINAC is configured to use a collimator angle as Non-IEC, the angle unit is given as [deg Non-IEC].*

The Field coordinate system definitions setting

The **Field coordinate system definitions** setting in RayPlan Physics defines how jaw and MLC leaf positions are reported and defined. The following description uses jaw naming convention according to the IEC 61217 standard.

Note: *If a LINAC is configured to use field coordinate system as IEC 61217, the unit for jaw and leaf positions are given as [cm].*

Note: *If a LINAC is configured to use field coordinate system as Non-IEC, the unit for jaw and leaf positions is given as [cm Non-IEC].*

Collimator positions according to IEC 61217

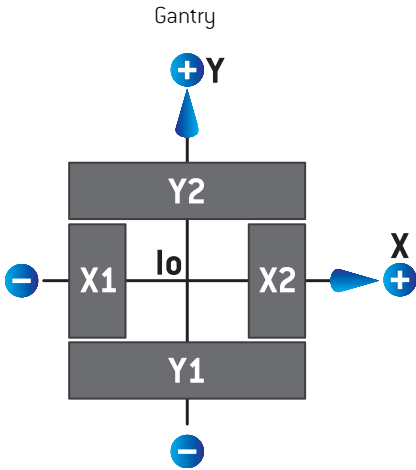

Figure 5. The collimator positions in the Beam's eye view according to the IEC 61217 standard.

The collimator positions according to the IEC 61217 standard, for a beam with (IEC) collimator angle 0 when viewed from the source, are described in the table below.

When the edge of...	is positioned to the ...	of the isocenter axis, its position reading value is ...
X1, X2 (jaw or MLCX leaf)	right	positive
X1, X2 (jaw or MLCX leaf)	left	negative
Y1, Y2 (jaw or MLCY leaf)	gantry side	positive
Y1, Y2 (jaw or MLCY leaf)	non-gantry side	negative

Collimator positions according to Non-IEC (Varian Standard)

For Non-IEC, positive position coordinates are reported in all directions for jaws and leaves that have not crossed the center line. That is, negative coordinates are reported for overtravel.

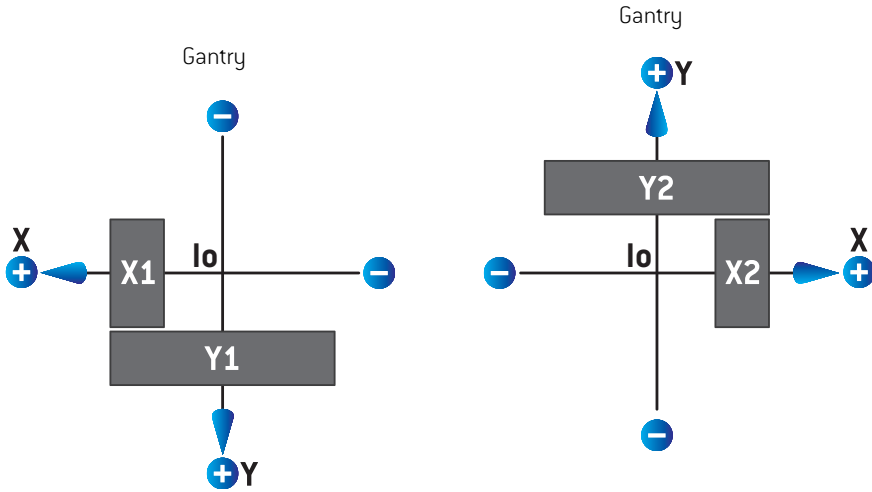

Figure 6. The collimator positions in the Beam's eye view according to the Non-IEC (Varian Standard). Note that the coordinates visualized in the Beam's eye view in RayPlan always uses the IEC 61217 coordinate system.

The collimator positions according to Non-IEC (Varian Standard), for a beam with (IEC) collimator angle 0 when viewed from the source, are described in the table below.

When the edge of ...	is positioned to the ...	of the isocenter axis, its position reading value is ...
X1 (jaw or MLCX leaf)	right	negative
X1 (jaw or MLCX leaf)	left	positive
X2 (jaw or MLCX leaf)	right	positive
X2 (jaw or MLCX leaf)	left	negative
Y1 (jaw or MLCY leaf)	gantry side	negative
Y1 (jaw or MLCY leaf)	non-gantry side	positive
Y2 (jaw or MLCY leaf)	gantry side	positive
Y2 (jaw or MLCY leaf)	non-gantry side	negative

The Jaw labeling standard setting

The **Jaw labeling standard** setting in RayPlan Physics is described in *section 5.4 The jaw and MLC labeling standard on page 83*.

5.3.4 The wedge filter coordinate system

The wedge filter coordinate system rotates with the wedge and the positive y axis points from heel to toe of the wedge. The wedge filter coordinate system has the beam limiting device coordinate system as its mother system. In RayPlan Physics and the main RayPlan 12A application, the wedge coordinate system is defined to coincide with the selected collimator coordinate system (IEC 61217 or Non-IEC) for a wedge orientation of zero degrees.

- For collimator coordinate system **IEC 61217**, the wedge orientation is zero degrees when the toe points towards the gantry for collimator angle zero.
- For collimator coordinate system **Non-IEC**, the wedge orientation is zero degrees Non-IEC when the toe points away from the gantry for collimator angle zero degrees Non-IEC.

The wedge orientation increases gradually for a counter-clockwise rotation.

Note: *If a LINAC is configured to use a collimator angle as IEC 61217, the wedge orientation angle unit is given as [deg].*

Note: *If a LINAC is configured to use a collimator angle as Non-IEC, the wedge orientation angle unit is given as [deg Non-IEC].*

5.3.5 The patient support coordinate system

The patient support coordinate system rotates with the part of the patient support that rotates around the vertical axis Z_s . The patient support coordinate system has the fixed coordinate system as its mother system.

- For **IEC standard**, the patient support system coincides with the fixed system when the couch angle is zero. The positive rotation direction is defined to be counter-clockwise as seen from above.

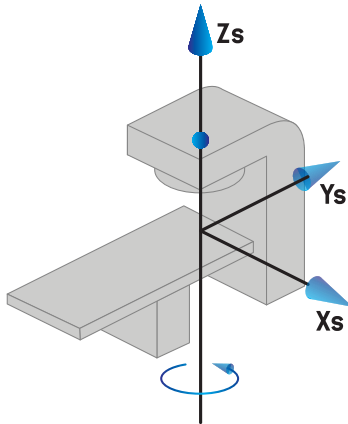

- For **Non-IEC 1 (Varian IEC)** machine scale, the patient support system coincides with the fixed system when the couch angle is zero. The positive rotation direction is defined to be clockwise as seen from above.

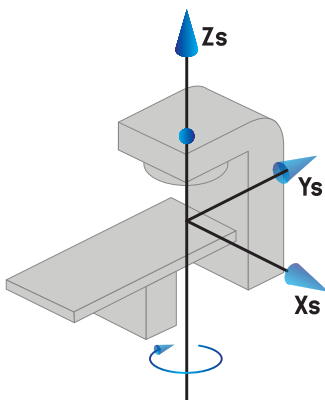

- For **Non-IEC 2 (Varian Standard)** machine scale, the couch angle is 180 degrees when the IEC couch angle is zero degrees. The positive rotation direction is defined to be clockwise as seen from above.

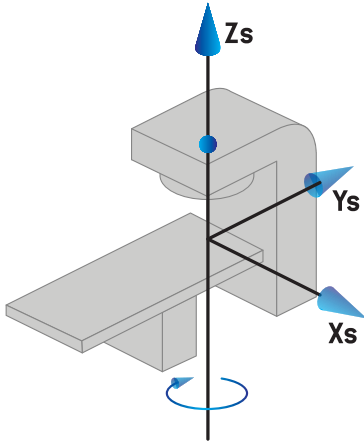

Note: *If a LINAC is configured to use couch angle as IEC 61217, the angle unit is given as [deg].*

Note: *If a LINAC is configured to use couch angle as Non-IEC 1 (“Varian IEC”), the angle unit is given as [deg Non-IEC] in the user interface and as [deg Non-IEC CW] in plan reports.*

Note: *If a LINAC is configured to use couch angle as Non-IEC 2 (“Varian Standard”), the angle unit is given as [deg Non-IEC] in the user interface and as [deg Non-IEC CW] in plan reports.*

5.3.6 The table top eccentric coordinate system

In RayPlan, only zero degrees eccentric table top rotation angle and zero translation distance are supported, and thus the table top eccentric coordinate system always coincides with the patient support coordinate system. The table top eccentric coordinate system has the patient support coordinate system as its mother system.

5.3.7 The table top coordinate system

In RayPlan, the table top coordinate system has the table top eccentric coordinate system as its mother system. Pitch and roll angles are always expressed using the IEC standard. Subsequent rotations are defined in the order pitch angle followed by roll angle.

- The table top pitch angle is defined as the rotation about axis X_t . An increase in the pitch angle corresponds to the clockwise rotation of the table top as viewed from the table top coordinate system origin along the positive X_t axis.

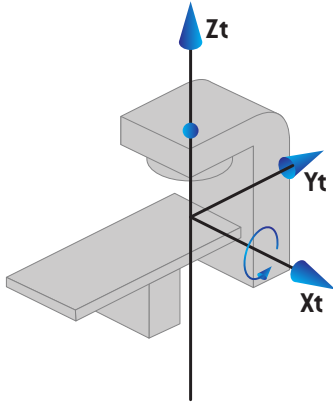

- The table top roll angle is defined as the rotation about axis Y_t . An increase in the roll angle corresponds to the clockwise rotation of the table top as viewed from the table top coordinate system origin along the positive Y_t axis.

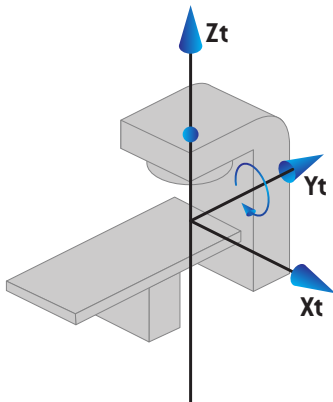

5.3.8 The CyberKnife radiation source coordinate system

The CyberKnife radiation source coordinate system moves with the CyberKnife radiation head and has its origin in the radiation source. The CyberKnife radiation source coordinate system has the fixed coordinate system as its mother system. For CyberKnife treatments, the CyberKnife radiation source coordinate system is the mother system of the beam limiting device coordinate system.

A set of six values defines the CyberKnife radiation source coordinate system in relation to its mother system. The six values are the source position coordinates (C_x, C_y, C_z) and the rotational angles (yaw, roll, pitch).

Source position

The source position (C_x, C_y, C_z) defines the position of the origin I_c of the CyberKnife radiation source coordinate system in coordinates of the fixed coordinate system.

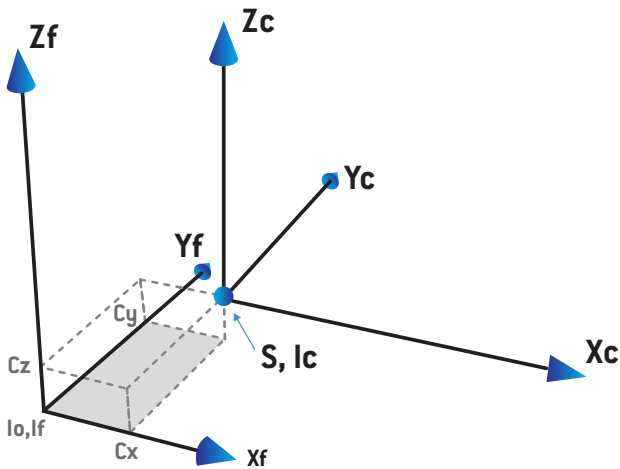
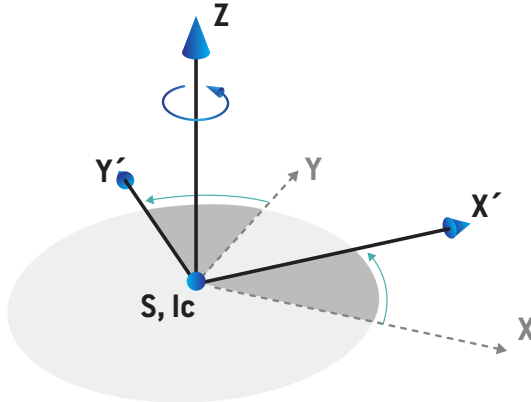

Figure 7. Illustration of the source position where I_o = Isocenter, S = Source, c = CyberKnife radiation source coordinate system and f = Fixed coordinate system.

Rotation

The three rotations yaw, roll and pitch define the orientation of the CyberKnife radiation source coordinate system in relation to its own reference orientation. In the reference orientation the angles yaw, roll and pitch are all 0, and the axes X_c, Y_c and Z_c are parallel to X_f, Y_f and Z_f respectively. The rotations are applied in the order yaw, followed by roll, and followed by pitch. Roll and pitch are rotations about the resulting axes of the former one or two rotations.

- **Yaw** is a rotation of X and Y around Z . The yaw angle increases gradually for counterclockwise rotation, observed from a point on the positive Z axis facing towards the origin. X , Y and Z are the axes of the reference orientation. X' , Y' and Z are the resulting axes from the yaw rotation.



- **Roll** is a rotation of Z and X' around Y' . The roll angle increases gradually for counterclockwise rotation, observed from a point on the positive Y' axis facing towards the origin. X_c , Y' and Z' are the resulting axes from the yaw rotation followed by the roll rotation.

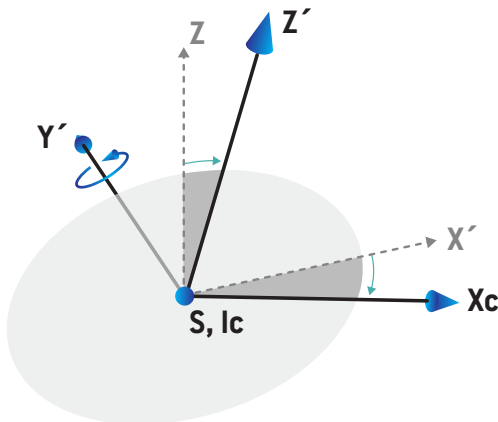

- Pitch** is a rotation of Y' and Z' around X_c . The pitch angle increases gradually for counterclockwise rotation, observed from a point on the positive X_c axis facing towards the origin. X_c , Y_c and Z_c are the final resulting axes after all three rotations; yaw followed by roll followed by pitch.

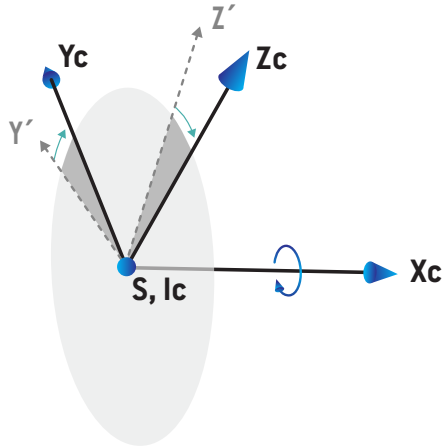

5.3.9 Dose curve coordinate system in RayPlan Physics

The Beam Commissioning module has a dose curve coordinate system corresponding to the IEC gantry coordinate system, translated so that the origin is on the central axis at the surface of the water phantom. The x-axis is aligned with the cross-line axis. The y-axis is aligned with the inline axis, with the positive direction towards the gantry. The negative z-direction, from source towards isocenter, is aligned with the depth direction. The gantry and collimator angles are always assumed to be zero degrees for the dose curves in the Beam Commissioning module. The model is fully reflection symmetric in the xz- and the yz-plane, whereas measurements can sometimes be mildly asymmetric.

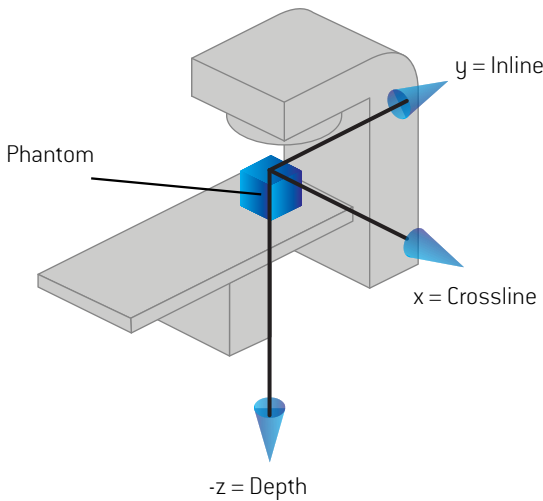

Figure 8. The dose curve coordinate system.

5.3.10 Setup imager coordinate systems

Setup imagers are in RayPlan described by the X-ray image receptor coordinate system. It is fixed in relation to the setup imager. The orientation of the X-ray image receptor coordinate system relative to the IEC fixed coordinate system is described using three rotations.

The first rotation is a gantry rotation about the y-axis of the fixed coordinate system, described in *section 5.3.2 The gantry coordinate system on page 70*.

Note: *The rotation is not necessarily a rotation of the treatment gantry, but a rotation about the y-axis of the fixed coordinate system. Setup imagers only support IEC gantry rotations.*

The second coordinate system, the gantry pitch coordinate system (Figure 9), has the gantry coordinate system as its mother system and is a rotation about the x-axis of the gantry coordinate system. When the gantry pitch angle is zero, the gantry pitch coordinate system coincides with the

gantry coordinate system. The positive rotation direction is clockwise when viewed from the origin along the positive x-axis of the gantry coordinate system. S_r is the imager radiation source.

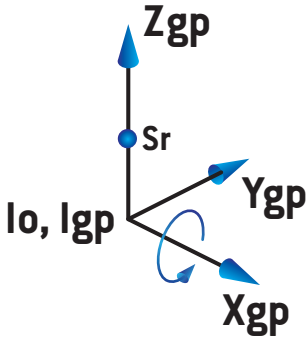

Figure 9. The gantry pitch coordinate system.

The X-ray image receptor coordinate system (Figure 10) has the gantry pitch coordinate system as its mother system and is a rotation about the z-axis of the gantry pitch coordinate system. When the X-ray image receptor angle is zero, the X-ray image receptor coordinate system coincides with the gantry pitch coordinate system. The positive rotation direction is counter-clockwise when viewed from a point on the positive z-axis facing towards the origin. S_r is the imager radiation source.

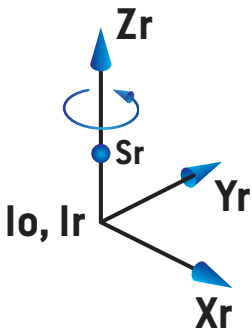

Figure 10. The X-Ray image receptor coordinate system.

Setup imaging systems and setup imagers

In RayPlan a setup imaging system consists of one or several setup imagers. Each setup imager is an imager radiation source with an associated image receptor. Setup imagers can be gantry-mounted or fixed in the treatment room.

Gantry-mounted setup imagers

A gantry-mounted imager moves with a gantry (treatment gantry or imaging gantry). A gantry-mounted imager can have a gantry angle offset.

A gantry-mounted imager only has a gantry rotation, i.e., the X-ray image receptor coordinate system coincides with the gantry coordinate system. The gantry rotation is given by the gantry angle of the beam or setup beam plus the imager gantry angle offset.

Fixed setup imagers

A fixed imager is fixed in the treatment room. A fixed imager can have all three rotations, i.e., gantry rotation, gantry pitch rotation and X-ray image receptor rotation.

5.4 THE JAW AND MLC LABELING STANDARD

In RayPlan 12A the jaws can be labeled according to one of the standards IEC 61217 or IEC 601-2-1. The description in this section uses the IEC 61217 Field coordinate system definitions setting.

5.4.1 The IEC 61217 jaw labeling standard

In **IEC 61217**, Y2 is close to the gantry and Y1 is away from the gantry, X1 is to the left and X2 to the right for an observer facing the gantry with gantry and collimator angle zero in the IEC 61217 coordinate system.

Gantry irradiating
from above

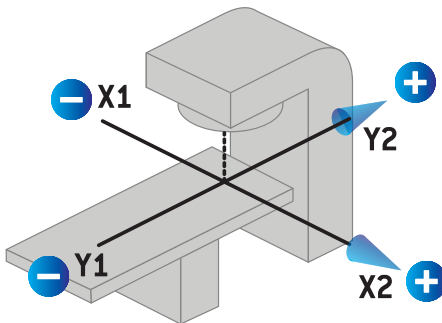

Figure 11. The jaw and MLC labels (IEC 61217).

5.4.2 The IEC 601 jaw labeling standard

In **IEC 601**, X1 is close to the gantry and X2 is away from the gantry, Y2 is to the left and Y1 to the right for an observer facing the gantry with gantry and collimator angle zero in the IEC 61217 coordinate system.

Gantry
irradiating from
above

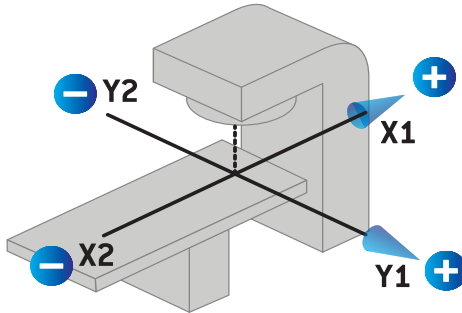

Figure 12. The jaw and MLC labels (IEC 601).

Note: *The jaw labeling standard setting only affects the names of the collimators in RayPlan and the Machine properties workspace in RayPlan Physics. Note that the coordinate axes are still labeled according to IEC 61217, examples being the dose curve labels and parameters in the Beam model workspace in RayPlan Physics.*

6 SYSTEM INTEGRITY AND SAFETY

This chapter describes the relevant processes related to system integrity and safety.

There is no need for the user to edit, add or remove parts of the system data. All modifications shall be performed by specially trained service personnel. Service personnel can assist in adjusting the system according to local IT policies. For guidelines on how to set up and maintain required and recommended security controls for RayPlan, see the *RSL-P-RS-CSG, RayPlan Cyber Security Guidance*.

System security alerts may be issued if RaySearch becomes aware of security vulnerabilities. Security alerts can be found in RayCommunity (the RaySearch online user community).

In this chapter

This chapter contains the following sections:

6.1	Protection against unauthorized use	p. 86
6.2	Backup routines and database maintenance	p. 86
6.3	Database access permissions	p. 87
6.4	ECC RAM	p. 87
6.5	System decommissioning	p. 87

6.1 PROTECTION AGAINST UNAUTHORIZED USE

The table below lists the various protection types in RayPlan 12A.

Protection type	Description
Password protection	All operating system user accounts must be password protected to prevent unauthorized access to the system and databases.
Network security	The risk of unauthorized network access needs to be assessed by the user organization. It is recommended to use security best practices to protect the integrity of the environment, for example, use of a fire-wall on the network and regular security patching of the computers.
Protection against unauthorized physical access	The risk of unauthorized physical access to an unattended session needs to be assessed by the user organization. It is recommended to use session time-out which can be set by the user using features of the Windows Active Directory.
Virus protection	State-of-the-art virus protection shall be enabled for all parts of the system including the entire computer network if present. This shall include automatic updates or similar to keep the protection up-to-date.
License protection	RayPlan 12A uses a hardware-based license protection system to prohibit usable copies of the system to be made.
Databases and checksums	To prohibit use of program or data files not belonging to the installed version of RayPlan 12A, the files are protected from exchange using checksums. The database design prevents modification of data storage other than using RayPlan 12A programs. The checksums on physics data files prevents modification of the files, or the application will not start.
Operating system administrator privileges	Tools enabling direct access to data stored in the databases shall be set up so as to require operating system administrator privileges.
Program code protection	RayPlan 12A program code and data shall only be accessed and modified as described in the manuals. Do not to tamper with program code or data!

6.2 BACKUP ROUTINES AND DATABASE MAINTENANCE

Database backup and restore shall be performed using a standard SQL database management tool. It is recommended that all RayPlan 12A databases (RayStationPatientDB, RayStationMachineDB, RayStationClinicDB and RayStationResourceDB) are set to recovery model full. This option makes it possible to run frequent backups and minimizes the risk of losing data in a database crash.

Maintenance type	Description
Regular backups	<p>Regular backups of all RayPlan databases should be scheduled and the success of these backups should be verified on a regular basis.</p> <ul style="list-style-type: none"> • Full backups: We recommend that full backups are performed as often as time, space and system usage allows. • Differential backups: We recommend that differential backups are performed as often as time, space and system usage allows. • Transaction Log Backups: We recommend that Transaction Log Backups are performed on an hourly basis – but the frequency can be increased or decreased based on the specific clinic needs. <p>It is recommended to bring a database backup off-site on a daily basis.</p>
SQL Server OS maintenance	<p>We recommend that the fragmentation on drives hosting the SQL data files should be checked for defragmentation. Where defragmentation is required this should be performed during maintenance windows.</p>
Indexing	<p>With additions, edits and changes to patient plans, the databases (particularly the Patient Database) can become fragmented. We recommend that an additional task to re-organize the databases is included in the database maintenance plan at an appropriate time (e.g., immediately following a full backup once a week).</p>

6.3 DATABASE ACCESS PERMISSIONS

The default permissions for database access include all Domain Users of the Active Directory within which the databases are installed. If preferred or required, the access rights of the individual databases can be controlled when created (refer to the RayPlan Storage Tool section in the *RSL-D-RP-12A-USM, RayPlan 12A User Manual*). For changes on ResourceDB, a procedure is available from support@raysearchlabs.com to restrict access to an appropriate AD group of users. The procedure will need to be repeated and access reviewed and confirmed as part of any RayPlan 12A upgrade activity.

6.4 ECC RAM

An Error-correcting code memory (ECC RAM) is required for CPU memory. This is a type of computer data storage that can detect and correct the most common kinds of internal data corruption.

6.5 SYSTEM DECOMMISSIONING

RayPlan stores personal and health-related data. When decommissioning a system, contact RaySearch support if needed to make sure that all storage locations for such data are identified.

A DEFINITIONS

Term	Meaning
BEV	Beam's Eye View
CBCT	Cone Beam Computed Tomography
CT	Computed Tomography
DCR	Digitally Composited Radiograph
DICOM	International standard to transmit, store, retrieve, print, process, and display medical imaging information
DVH	Dose Volume Histogram
deg	When the term deg is seen in RayPlan 12A this refers to degrees
DMLC	Dynamic Multi-Leaf Collimator
DRR	Digitally Reconstructed Radiograph
EUD	Equivalent Uniform Dose
External ROI	The ROI used to define patient outline. Defines the region used for dose computation, together with BOLUS for beam, SUPPORT and FIXATION ROIs.
FoR	Frame of Reference
GUI	Graphical User Interface
HDR	High Dose Rate
IMRT	Intensity Modulated Radiation Therapy
LINAC	Linear accelerator, conventional radiation therapy treatment unit.
MBS	Model-Based Segmentation
MU	Monitor Units
OAR	Organ at risk
POI	Point of Interest
ROI	Region of Interest
ROI Geometry	The image set-specific geometric representation of an ROI

Term	Meaning
SMLC	Segmental Multi-Leaf Collimator
SSD	Source to Skin Distance
SUV	Standardized Uptake Value
UI	User Interface
VMAT	Volumetric Modulated Arc Therapy

INDEX

A

- Accuracy
 - electron dose engine 19
 - photon dose engine 16
- Associated documentation 9

B

- Backup routines 86
- Beam limiting device coordinate system 71
- Build number 20

C

- Contact information 13
- Coordinate system
 - dose curve 81
- Coordinate systems
 - patient coordinate system 65
 - treatment machine coordinate systems 65

D

- Database access permissions 87
- Data communication environment 64
- Definitions 90
- Dose curve
 - coordinate system 81

E

- Electron dose engine accuracy 19

F

- Field coordinate system definitions setting 71

G

- Gantry coordinate system 70

H

- Hardware 12

I

- Import of patient data 62
- Intended use 12
- Intended user 12

J

- Jaw labeling standard 83

L

- Label 20
- License protection 86
- Lifetime 21

M

- Machine scales 65

O

- Operating system 12

P

- Patient coordinate system 66
- Patient support coordinate system 75
- Photon dose engine accuracy 16

Product label 20
Product name 20
Product version 20
Protection against unauthorized use 86

R

Regulatory representatives 13
Reporting of errors 13

S

Safety precautions 24
Software build number 20

System environment acceptance test 64

T

Treatment machine coordinate system 68–
69

V

Virus protection 86

W

Wedge filter coordinate system 74



CONTACT INFORMATION



RaySearch Laboratories AB (publ)
Eugeniavägen 18C
SE-113 68 Stockholm
Sweden

Contact details head office

P.O. Box 45169
SE-104 30 Stockholm, Sweden
Phone: +46 8 510 530 00
Fax: +46 8 510 530 30
info@raysearchlabs.com
www.raysearchlabs.com

RaySearch Americas

Phone: +1 877 778 3849

RaySearch France

Phone: +33 1 76 53 72 02

RaySearch Korea

Phone: +82 10 2230 2046

RaySearch Australia

Phone: +61 411 534 316

RaySearch Belgium

Phone: +32 475 36 80 07

RaySearch Germany

Phone: +49 30 893 606 90

RaySearch Singapore

Phone: +65 81 28 59 80

RaySearch China

Phone: +86 137 0111 5932

RaySearch Japan

Phone: +81 3 44 05 69 02

RaySearch UK

Phone: +44 2039 076791

